



This is a digital copy of a book that was preserved for generations on library shelves before it was carefully scanned by Google as part of a project to make the world's books discoverable online.

It has survived long enough for the copyright to expire and the book to enter the public domain. A public domain book is one that was never subject to copyright or whose legal copyright term has expired. Whether a book is in the public domain may vary country to country. Public domain books are our gateways to the past, representing a wealth of history, culture and knowledge that's often difficult to discover.

Marks, notations and other marginalia present in the original volume will appear in this file - a reminder of this book's long journey from the publisher to a library and finally to you.

Usage guidelines

Google is proud to partner with libraries to digitize public domain materials and make them widely accessible. Public domain books belong to the public and we are merely their custodians. Nevertheless, this work is expensive, so in order to keep providing this resource, we have taken steps to prevent abuse by commercial parties, including placing technical restrictions on automated querying.

We also ask that you:

- + *Make non-commercial use of the files* We designed Google Book Search for use by individuals, and we request that you use these files for personal, non-commercial purposes.
- + *Refrain from automated querying* Do not send automated queries of any sort to Google's system: If you are conducting research on machine translation, optical character recognition or other areas where access to a large amount of text is helpful, please contact us. We encourage the use of public domain materials for these purposes and may be able to help.
- + *Maintain attribution* The Google "watermark" you see on each file is essential for informing people about this project and helping them find additional materials through Google Book Search. Please do not remove it.
- + *Keep it legal* Whatever your use, remember that you are responsible for ensuring that what you are doing is legal. Do not assume that just because we believe a book is in the public domain for users in the United States, that the work is also in the public domain for users in other countries. Whether a book is still in copyright varies from country to country, and we can't offer guidance on whether any specific use of any specific book is allowed. Please do not assume that a book's appearance in Google Book Search means it can be used in any manner anywhere in the world. Copyright infringement liability can be quite severe.

About Google Book Search

Google's mission is to organize the world's information and to make it universally accessible and useful. Google Book Search helps readers discover the world's books while helping authors and publishers reach new audiences. You can search through the full text of this book on the web at <http://books.google.com/>

U G

470

B3

UC-NRLF



QB 261 968

MILITARY MAP READING
AND
INTELLIGENCE TRAINING

BY

CAPTAIN C. D. A. BARBER, C. E. F.
"CANADIANS"



EX LIBRIS







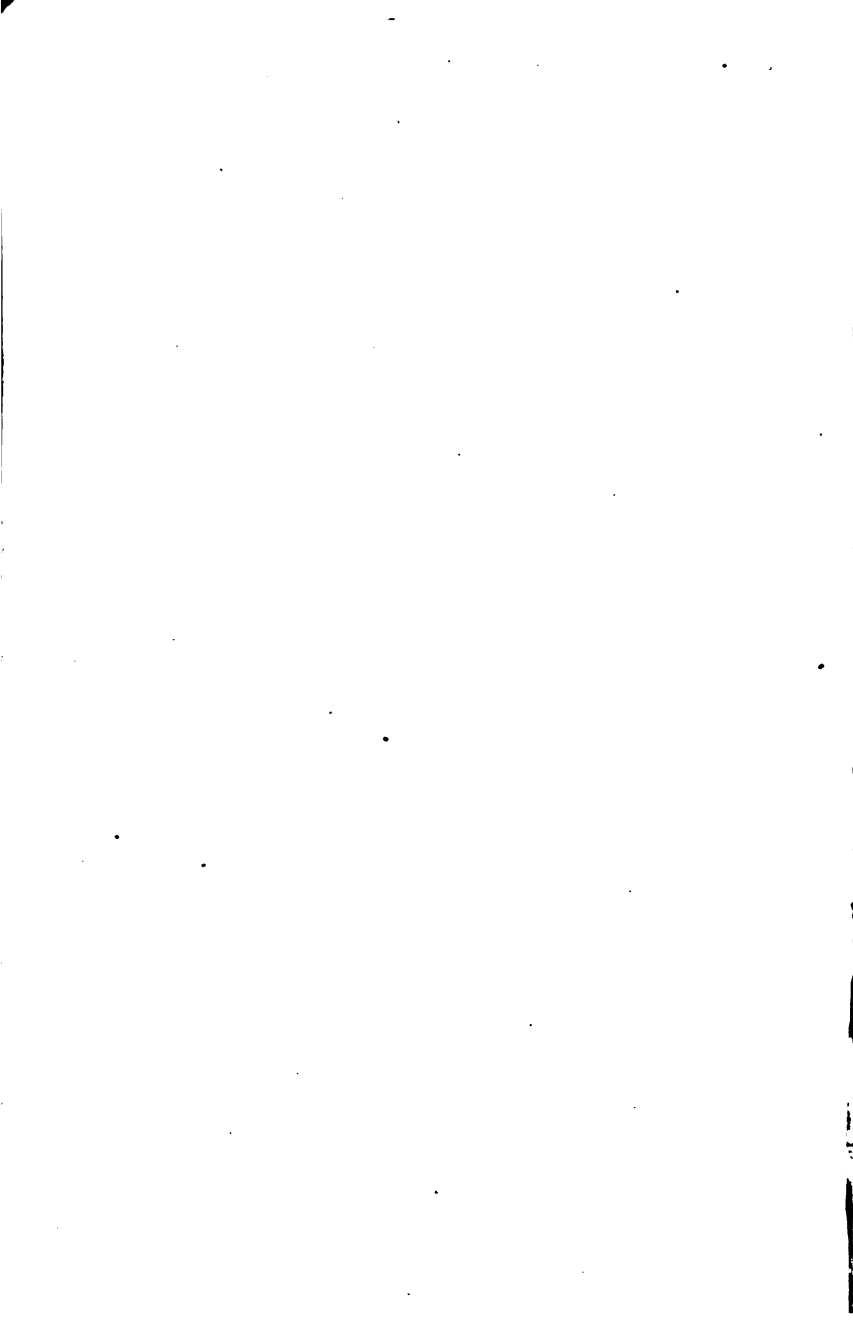

MAP READING
and
INTELLIGENCE TRAINING

BY
CAPTAIN C. D. A. BARBER
Late Intelligence Officer
202nd "Sportsmen's" Battalion, C. E. F.
"CANADIANS"

Published by Permission
Chief of Staff, Ottawa, Canada

Recommended by
Director of Military Training
Canada

For Sale By
E. C. McKay, 409 Sweetland Building
Cleveland, Ohio

Price \$2.50

ALL RIGHTS RESERVED

PENTON PRESS CO., CLEVELAND, OHIO

UG 470
I 2

COPYRIGHT 1917
BY EDWARD C. MCKAY
CLEVELAND, OHIO

Preface

Map Reading and the Training of the Intelligence Section, i. e., Scouts, Snipers and Observers are a group of subjects which every officer should personally take an interest in.

Not only because they are, as subjects, most interesting, but because they are of the most vital importance when in actual warfare.

To be unable to take a map of a strange sector of country, and thoroughly understand what every line and sign means, is to be helpless in the face of the enemy.

Consequently, I would advise every officer, N. C. O and man to improve his knowledge on map reading and its component parts, as active service in war will call on them every day for a thorough understanding of this subject.

LIEUT. COL. R. B. HAMILTON,
Late O. C. Queen's Own Rifles.

Cleveland, Ohio.
Nov. 15, 1917.

369564

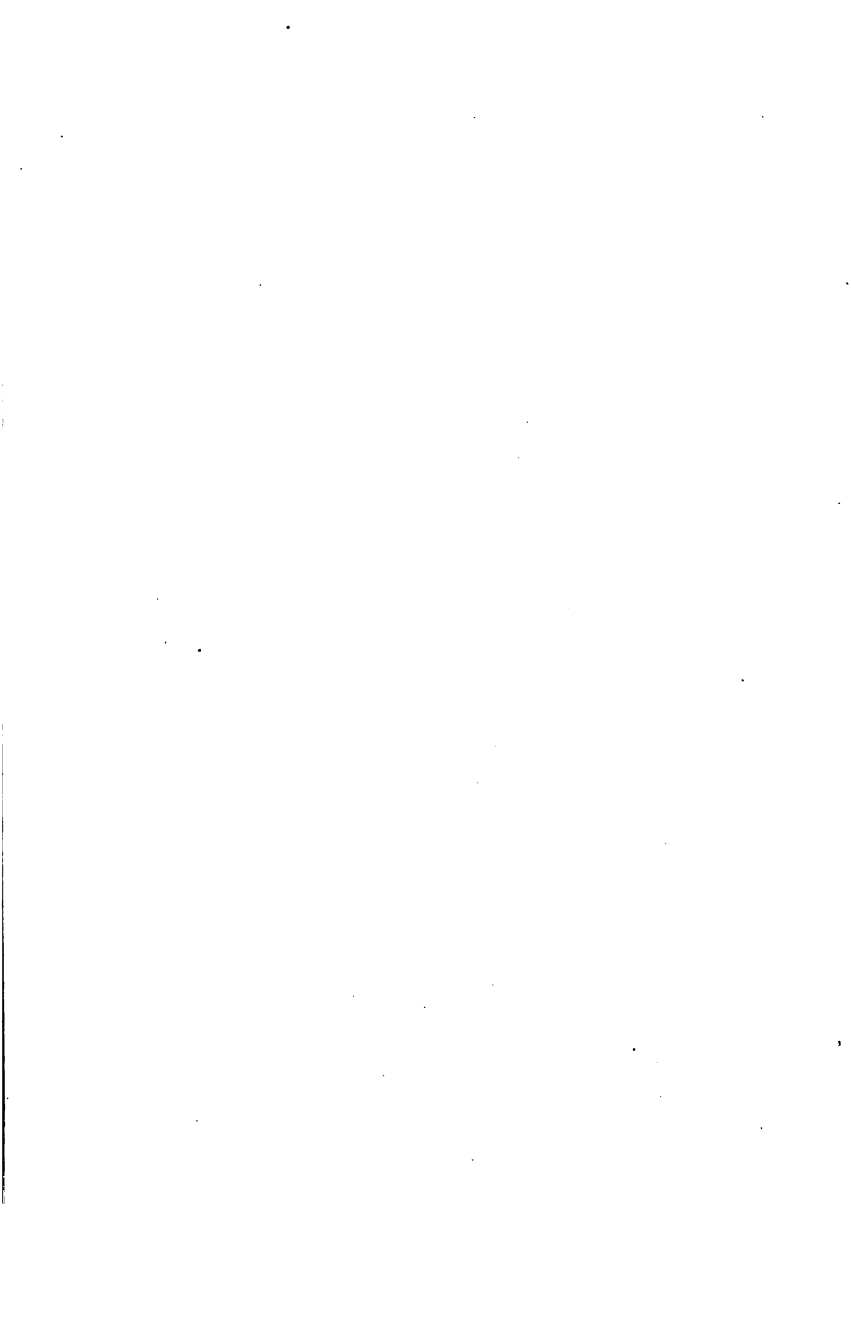

Foreword

After two and a half years instructing in the subject of "Military Map Reading and the Training of Scouts, Snipers and Observers" I have concluded that a great amount of assistance can be given to the officers and men now starting on preliminary work by combining under one cover a general outline of their duties, or set of notes for them to follow.

It has been my experience that an officer taking up this branch of service would refer to six or more text books out of which he took parts and incorporated them into his Syllabus of Training. This caused a very decided variation in the method of training and often the same authorities were not quoted, which was by no means a success in giving the men the best training.

The information in this copy of "Military Map Reading and Intelligence Training" is strictly along the lines laid down by the regulations and in a number of instances has direct quotations from the best authorities. However, the greater part is entirely new, especially the cuts, plates and photographs, and I only hope that the book will help the boys who take up his most interesting and important part of infantry training.

THE AUTHOR.

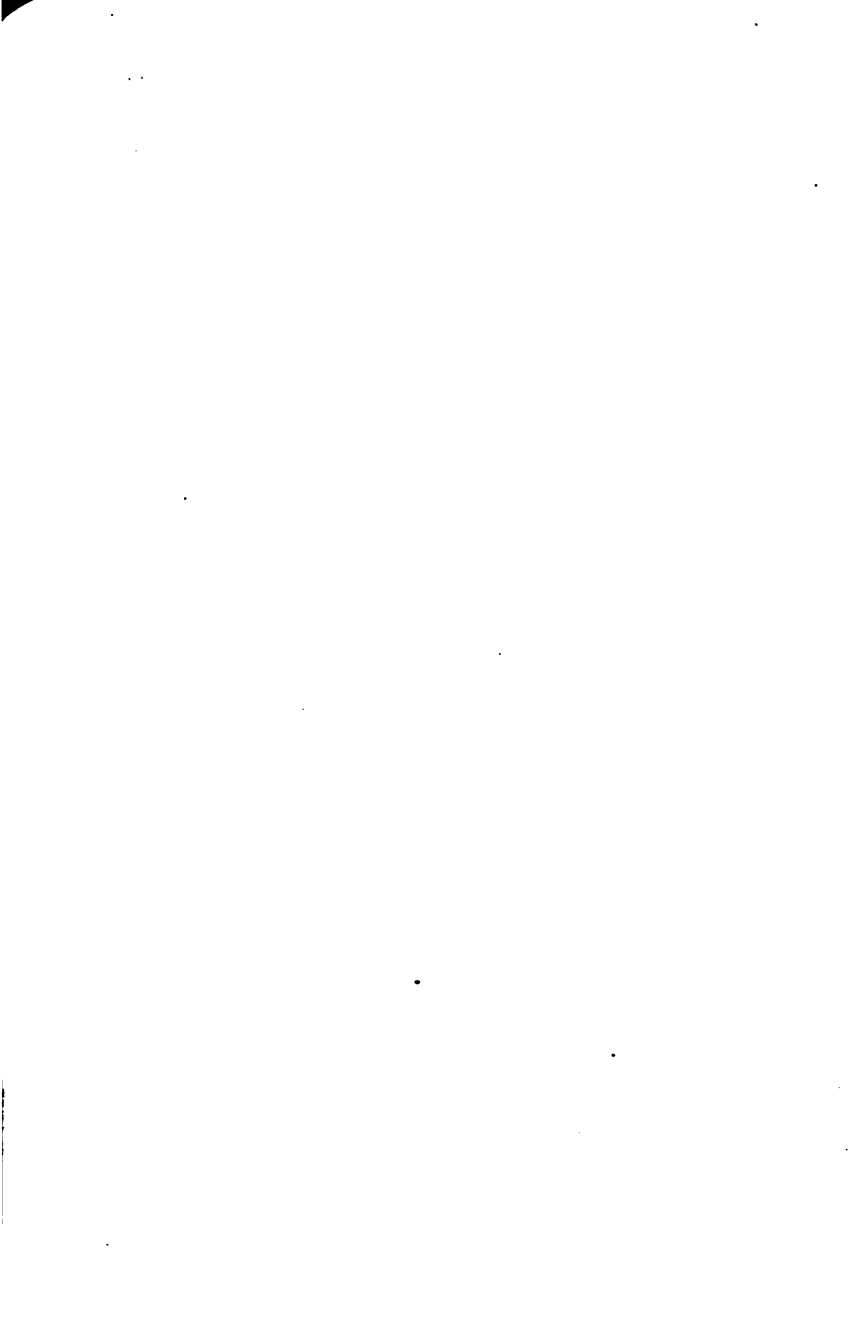





INTELLIGENCE SECTION—N. D. BATTALION, CANADIANS

Military Map Reading and Intelligence Training

By Captain C. D. A. Barber

PREFACE TO THE FIRST EDITION

Part 1—The Intelligence Section.

Selection of Officers, N. C. O.'s and Men. Syllabus of Training, Subjects Taken Up. Notes on Arranging Syllabus. Sample Syllabus. Aliens in the Ranks. Interrogation Forms.

Part 2—Map Reading.

First Principles. True and Magnetic North. "Setting" a Map. Scales. Representing Hill Features. Conventional Signs. Topographical and Technical Definitions. Traversing. Plotting Traverse. "Bearings". Resectioning. Triangulation. Squaring Service Maps.

Part 3—Instruments and Equipment.

Mark VII. Prismatic Compass. Trench Sniperscope. Telescope Rifles. Heavy Calibre Rifle. Periscopes. Range Finders. Field Glasses. Machine Gun Levels. Mounting Maps. Protractors. Fixed Rifle Stands.

Part 4—Information, Reconnaissance and Observation.

Reports on Different Kinds of Topography. Scouts on Patrols in Open Warfare. Trench Warfare. Walking and Crawling Practices. Trench Raids.

Part 5—Reports, Messages and Orders.

Construction of Same. Sample Reports from Scouts on Observation. Scouts on Patrols. Snipers on Duty. Intelligence Officers. Operation Orders.

Signaling. Morse Flag. "Buzzer" Phone. Semaphore. Wireless. International Code. Miscellaneous Army Signals. Prefixes. Army Forms.

Part 6—Trench Warfare.

Sniping and Observation. Selection of Men. Special Training. Details of Trenches. Reports Required. Discipline. Fixed Rifle. Theory of Fixed Rifle Fire. Dugouts. Snipers' Posts. Observation Posts. Wire Entanglements.

Part 7—Aeroplanes.

As Scouts. Aeroplane Photographs and Maps. Method of Taking and Using.

Part 8—General Information.

Sanitation and Care of the Feet. Defensive Measures Against Gas. Wind Observations and Reports. Aeroplane Emblems, *Translation German Documents*. Meteorological Data. Trajectory Data.

- - - - decrease.

- - - -

- - - - East

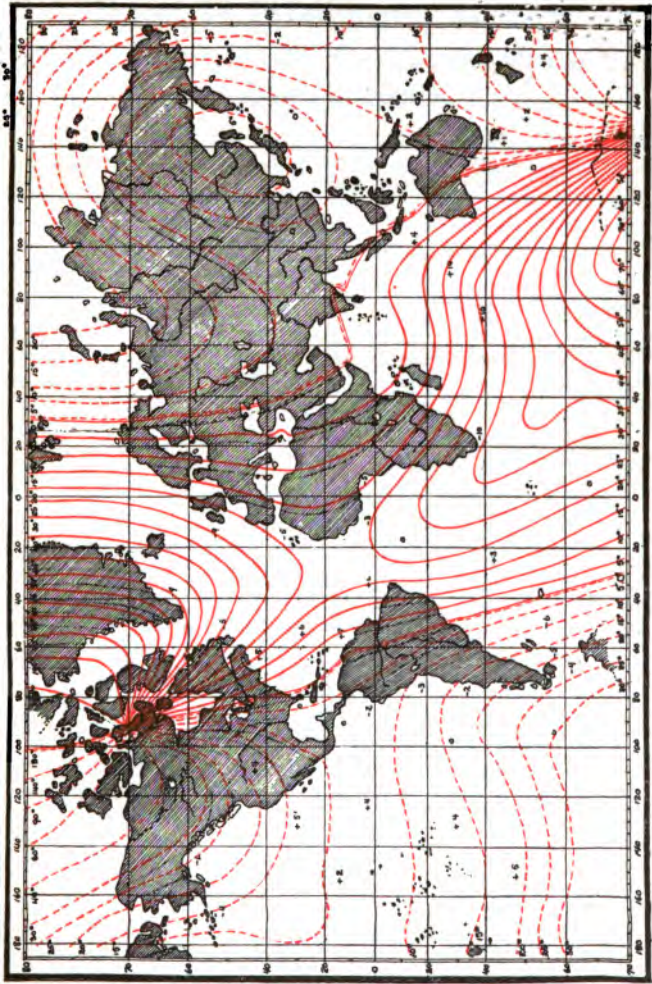

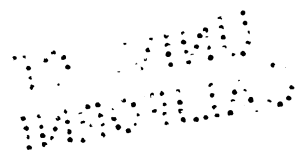

Object of Intelligence Section

Selection of Officers, N. C. O.'s and Men of the Intelligence Section

As time goes on, and more and more experience is gained in the present great war, the importance of the intelligence section, its personnel and training, is receiving closer attention and more earnest support of every senior officer in the army.

Probably the **most important item** towards laying the foundation for a really up-to-date and efficient intelligence section, is in the first selection by the commanding officer of a new battalion, of the junior officer, who is to lead and take charge of the instructional work of his intelligence section.

The commanding officer must make up his mind to give up his very best junior officer for this work. He must carefully check over the various officers' qualifications, and pick out a man who in civil life has already received some of the ground work.

Many of the young officers have the qualifications for this work, and it is generally only a question of locating them. It seems a pity to waste time and send to the instructional school an officer who does not take any interest in this important branch of the service, and then put him in charge of a smart squad of men, in whom he does not take enough interest to give them the training and attention necessary—when, no doubt, there is in charge of one of the platoons an officer who, if given a chance, would make good in every way.

There is usually to be found in every battalion at least one or two officers who in civil life followed as his livelihood railroad or civil engineering, prospecting or exploring. These officers know the difficulty they have to overcome in teaching advanced map reading and the necessity for this

knowledge in the field. Given the other necessary qualifications of good health, first class eyesight, cool and steady judgment in tight corners, interest in teaching his men the work, and you have on hand a real intelligence officer who can proceed with his work and carry it out in a most satisfactory manner to all concerned.

A second and even a third officer should be selected and allowed to work at times with the intelligence officer and his men, in order to become conversant with the work and qualifications of the men in the section, then when the battalion comes under fire and an accident should happen to the intelligence officer or his non-commissioned officers, another officer would be available at once to take charge and carry on with the operation.

The selection of the N. C. O.'s is second only to that of the officer in charge. Intelligent, active men, keen for their work, experts in map reading and fully conversant with the class of work they are undertaking, and marksmen with the rifle and revolver, are the men to be selected.

In picking out the rank and file for the intelligence section, the commanding officer of the battalion should leave this entirely in the hands of the intelligence officer, because if the proper officer has been given charge of the intelligence section he will know who the proper men are for his purpose. The class of men most suited for this work are bright, active young fellows, who have followed an outdoor life, have the best of health and a good education; they must have these qualifications to start in on, as their work often places them in situations alone and entirely dependent on their own resources, at which time their early training will stand them in good stead.

Every man who is selected for the intelligence section must be a good shot, and have received all the possible training in musketry and actual firing on the range that can be given him. In the case of

the snipers, special firing with the telescope sights must be arranged for, but not until after he has had his full training in musketry and with the open battle sights.

If these few suggestions are followed out, the intelligence officer is given the assistance to secure the equipment at an early date that he should have, then the battalion will have a section that will be a credit to them and their division. Such a section may be the means of extricating the battalion from more than one trying situation.

Suggested Syllabus of Training, Scouts, Snipers and Observers

- (1) **Lectures should be given on—**
 - (a) Action of infantry, scouts, snipers and observers generally.
 - (b) Training of scouts, snipers and observers.
 - (c) Organization of the intelligence section.
 - (d) Matters enumerated in (2), (5), (6), (7), (8), (9), (10) and (11).
 - (e) Organization, uniform and strength of units of all arms in the principal continental armies.
- (2) **Elementary instruction in map reading—**
 - (a) Definitions of topographical forms.
 - (b) What is meant by the scale of a map.
 - (c) Explanation of the usual conventional signs used.
 - (d) Full explanation of the usual methods employed to show hill features on a map.
 - (e) Use of maps in the field.
 - (f) Explanation of true and magnetic meridian, also definition of a "bearing".
 - (g) How to "set" a map.
 - (h) Copying, enlarging and making maps (especially trench and squared maps).
- (3) **Map reading on the ground—**
- (4) **Visual training.**
- (5) **Judging distance.**

- (6) **Morse "buzzer" and flag signalling.**
- (7) **Rules regarding reports and messages.** (Too much training and actual practice in this branch cannot be done, as it is a most difficult matter to get the proper ideas as to the construction of reports and messages into the ordinary man.)
- (8) **Physical training.**
 - (a) Long-distance walking and running in ordinary uniform.
 - (b) Breathing, trunk, arm, leg, neck, abdominal and dorsal exercises.
 - (c) Football players and other athletes should be encouraged to take up scouting, sniping and observation work, and one of each pair of scouts should be a trained runner.
- (9) **Practical instruction (both individual and collective) must be given in the following:**
 - (a) Covering the advance of a company during the early stages of a battle.
 - (b) Acting as scouts sent out from an advanced guard, either to the front, or to the flanks.
 - (c) Acting as a reconnoitering patrol from a picket on outpost duty.
 - (d) Acting as scouts and snipers left by a rear guard.
 - (e) Acting as scouts and snipers left to cover a retirement.
 - (f) Receiving, carrying and delivering a verbal or written message.
 - (g) Finding the way back to a point from which a start was made.
 - (h) Remembering ground once passed over and thus training to act as guides.
 - (j) Training in power of observation. (The intelligence officer should go over the

tract of country or routes selected for the exercise, and make notes on all that he observes, each scout or observer on reaching the appointed rendezvous should be questioned separately as to the points which should have been noted by him enroute.)

- (k) Trench and open warfare.
- (10) **Bombs and their construction.**
 - (a) Bomb throwing.
 - (b) Use of flares and rockets.
 - (c) Use of mines and demolitions.
 - (d) Trench bombing tactics, by day and night.
- (11) **The rifle and its use:**
 - (a) Musketry.
 - (b) Practical work in the field.
 - (c) Firing on the ranges.
 - (d) Zeroing of telescope and battle sights.
 - (e) Telescope rifles.
 - (f) Range finders.
 - (g) Sniperscopes.
 - (h) Vigilant glasses and periscopes.
 - (i) Revolvers and their practical use.
 - (j) Proper use of field glasses and telescopes.
 - (k) Synchronization of watches.

Notes on the Syllabus.

1. Don't lecture your men for more than three-quarters of an hour at a time on any one subject.
2. Make your lessons just as interesting as possible.
3. Encourage groups and individuals to compete against one another, they get their work up much better under these conditions.
4. Have your men play games among themselves, join them as much as possible; in this way you will get a line on the temperament of each man, and will probably discover that you have an odd man you would like to get rid of.

5. **A good scout, sniper or observer** usually has plenty of nerve when he is thoroughly up on his work and has confidence in his own ability; this rule holds good particularly with good rifle shots.

6. If possible have all the men **learn to ride** both a horse and a motorcycle; there have been many cases where the knowledge has been of great service.

7. When your men **go on leave**, ask them to keep in touch as much as possible with their work, they can greatly improve their powers of observation every day by noting the most ordinary happenings.

8. **Don't tell them they are perfect** in their work, no matter how good they may be. Let them know when their work has been carried out well, or the reverse, but always look for and expect further improvement.

9. **The men of the intelligence section** should be looked up to by every man in the battalion, and should always be ready to assist others and give good advice.

10. **Don't let the men overlook or neglect** their feet at the end of a day's route march; a little time taken to bathe and reduce the blisters means everything in keeping the feet in proper condition.

11. **Encourage them to think out** new ideas that will make the work more efficient; new types of snipers' posts and observation posts are continually being devised, and most of these are planned by members of the sections themselves.

12. **Encourage the study of languages**, especially German. Arrange if possible for some good instructor to give the section one hour a day, after they get along with their other work for two months. The right stamp of man will be greatly interested, and while it means hard work, well repays the extra work.

SYLLABUS OF TRAINING.

Battalion C. E. F.

Week ending 19.....

	MONDAY	TUESDAY	WEDNESDAY	THURSDAY	FRIDAY	SATURDAY
Physical Training.....	† 8 to 9 A.M.	† 8 to 9 A.M.	† 8 to 9 A.M.	† 8 to 9 A.M.	† 8 to 9 A.M.	† 8 to 9 A.M.
Morse Signalling.....	† 9:15 to 10:15 A.M.	† 9:15 to 10:15 A.M.	† 9:15 to 10:15 A.M.	† 9:15 to 10:15 A.M.	† 9:15 to 10:15 A.M.	† 9:15 to 10:15 A.M.
Map Reading.....		*10:30 to 11:45 A.M.L.		*10:30 to 11:45 L.		
Definitions.....						
Scales.....			*10:30 to 11:45 A.M.L.		*10:30 to 11:45 A.M.L.	
Conventional Signs.....						
Magnetic Compass.....		†11:45 to 12:30 P.			†11:45 to 12:30 P.	
Bearings.....						
Map Setting.....						
Traversing.....	*10:30 to 12:30 L.			†11:45 to 12:30 P.		
Reconnaissance.....			§11:45 to 12:30 P.			
Copying and Enlarging.....						
Making Maps.....	*1:30 to 2:30 P.M. P.		*1:30 to 2:30 P.M. P.	*1:30 to 2:30 P.M. P.	*1:30 to 2:30 P.M. P.	
Aeroplane Maps.....						
Adjusting Scales.....		*1:30 to 2:30 P.M. P.†				
Reports and Messages.....		†2:30 to 3:30 P.M. P.				
Squared Map Work.....						
Panoramas.....						
Visual Training.....	†2:30 to 3:30 P.M. P.		†2:30 to 3:30 P.M. P.		†2:30 to 3:30 P.M. P.	
Judging Distance.....						
Instruments.....						
Bombing.....		†3:30 to 4 P.M. P.			†3:30 to 4 P.M. P.	
Gas Training.....						
Musketry.....		†3:30 to 4 P.M. P.			†3:30 to 4 P.M. P.	
Special Information.....						
Running.....						
Night Work.....		§4 to 4:30 P.M. P.			§4 to 4:30 P.M. P.	
Examinations.....						
Holiday.....						*10:30 to 12:30 P. 12:30 on.

Place—† Parade Grounds. † Field Training Area.

* Class Room. § On Country Roads.

L.—Lecture. P.—Practical.

Remarks.

Lieut.

Officer i/c Intelligence Section.

Size of sheet 12" x 14".

Examination of Aliens in the Ranks.

By Permission.

Intelligence.

On account of the extensive and unscrupulous character of the German spy system, no instrument being too humble and no method being too base for use, it has been found necessary to keep up a systematic counter intelligence.

Investigation.

Every man, an alien or of alien stock now in uniform, or who may come in by any of the drafts from home, should be listed and carefully investigated immediately after they arrive. The importance of this cannot be overestimated.

Interview.

The best method of investigation is to interview all such persons, then no one is being warned by being singled out. The interview should go carefully into the personal and family history of the "subject", many questions having no direct bearing on his character being asked, the statement being written down and signed by both the soldier and examining officer and dated. Immediately on dismissing the soldier the examining officer should record on the form his personal impressions of the man, and whether or not he should be kept under observation.

Reason for Examination.

At the outset of the interview, the examining officer should explain candidly to the soldier the reason for examining him, viz., that a large number of aliens have joined the forces, and it is necessary for us to know who they are; and that they are all to be examined, in order that no man may feel that he is being singled out.

Each man should be dismissed feeling that he is quite free of suspicion. If he feels safe he will be emboldened and will be the easier detected.

Five Sorts of Dangerous Persons.

There are five sorts of dangerous persons with whom you have to deal:

1. The present active spy who is all the time gathering information and giving it to the enemy.

2. The man who has no present communication with the enemy, but who will watch his chances, on the field of battle, to communicate with the enemy, with or without desertion.

3. The man who has no present formed evil intentions, but whose heart is not in our work, and who, if things went bad with us, would desert to the enemy, by desertion or otherwise.

4. The alien-born man of the adventurous type, willing to sell to the highest bidder, and who would make any little row with his N. C. O. or a comrade a sufficient reason in his own mind to go and seek out a buyer.

5. The man who enlisted thinking the war would end before he would be sent to the front.

Unit Intelligence Officer.

It would be impossible for the headquarters intelligence officer to interrogate all the aliens, so it is necessary to have an intelligence officer with assistants in each unit detailed to handle this duty as part of their regular work. A staff officer in each brigade will act as brigade intelligence officer.

Consultation and Reports.

In cases of difficulty the unit intelligence officer will consult with the headquarters intelligence officer, and the latter should be kept fully informed as to all suspicious cases and circumstances. In this connection all unusual happenings, incidents and rumors of any kind should be reported and no means left unturned to keep the intelligence department fully advised as to what is going on in your vicinity.

Outside Communications.

All communications with any outside or civil authorities will be through the headquarters intelligence office only.

Communications.

All communication with headquarters intelligence should be through the usual channel, i. e., brigade headquarters except in very urgent cases, which should be sent direct to headquarters intelligence office, and a copy forwarded to the brigade so that they may be fully advised.

Letters, however, arriving for suspects, which are to be scrutinized, should be sent direct to headquarters intelligence office, and if possible by special messenger, to prevent delay and suspicion. All letters relating to intelligence matters should be addressed "Intelligence Officer" headquarters.

Regular Visit.

An officer from the intelligence office should visit the brigade and unit intelligence officers regularly to advise and assist them in every way and also at same time check their work.

Interrogation Form.

Interrogation forms along the lines of the following are found suitable to make a record of questions answered by the soldier, and may be added to on back of form as circumstances require. These forms as soon as completed, are to be forwarded to the headquarters intelligence office.

The intelligence department requires the full co-operation of all ranks in this most important work.

**Form for Employers of Any Kind of Plant
Interrogation Form.**

No..... Rank..... Name.....
 Regt..... Co..... Original Unit.....
 Date and place of birth.....

Height..... Weight..... Color Eyes..... Hair.....
 Color Eyebrows..... Beard..... Moustache.....
 Peculiarity of appearance or identification marks.....

.....
 Education
 Religion
 Civil occupation.....
 Date you left home to earn a living and history since...

.....
 What languages do you speak?.....
 What languages do you read?.....
 What languages do you write?.....
 Could you act as interpreter in above languages?.....
 What previous military experience?.....
 Where and when did you enlist?
 WHY did you enlist?.....
 Place and date of naturalization.....
 Are you married?.....
 Wife's original nationality.... How many children?....
 Wife's maiden name and present address.....

.....
 Father's name in full.....
 Address if living or place of decease.....
 Father's nationality and occupation.....
 Mother's maiden name..... Nationality.....
 Address if living or place of decease.....
 Man's signature
 Remarks of examining officer.....

.....
 Date and place
 Examining Officer
 Unit.

Suggestions for Unit Intelligence Officers.

1. **Proceed at once** to organize your unit intelligence section, get one or two wide-awake men in each company, preferably men with police or detective experience, to assist you and to bring you information. **They should not know one another**, and should report fully anything of a suspicious nature that may come to their notice, not only in their own unit, but outside as well.

2. Next proceed to **clear up the situation as to aliens** in your own unit, and when drafts arrive from home, deal with them promptly. Get a list of all the aliens, or those of alien descent, from the platoon commanders, as well as from the attestation or registration forms.

3. Your examination of aliens and those of alien stock, as suggested in the interrogation form, will eliminate at once a large number as to whom you will have satisfied yourself as to their good faith. Have every man sign their own interrogation form.

4. **Keep a secret list** on which you will mark those who in your opinion are "cleared" and "not cleared".

5. Before forwarding the original statements to the intelligence office, make and **keep a copy of the statement** of all those "not cleared" for your own reference.

6. Every man on conclusion of your examination is to be made to feel that he is not under suspicion. The bad ones will thus be emboldened and will be easier detected.

7. **All mail** coming to men "not cleared" is to be forwarded direct to the headquarters intelligence officer for examination.

8. All communications with outside authorities will be through the intelligence department headquarters only.

9. When any suspected person is going on leave the bona fide address he gives is to be forwarded immediately to the headquarters intelligence officer, so that arrangements may be made to watch his actions and movements.

10. All soldiers of whatever rank, aliens or not, who apply for passes with undue frequency are to be considered as under suspicion. Innocent themselves, they sometimes come under the influence of women who are in the enemy's employ; prostitutes who very often are active spies for the enemy and are much used in that capacity.

11. Descriptions are usually faithfully given, but this portion of the examination is of minor importance.

12. Education. The quality, whether "good", "medium", "fair", is information of no value. What is desired is the character of education, whether public or private schools, colleges or universities and in what country, **in order to determine the influence of thought, if any on the man being examined.**

13. It is not sufficient that a man, born, say in Canada and coming to the U. S. A. a few months prior to enlisting, whose parents were of alien birth, to say that his reason for enlisting was "patriotism". **Question him further as to what prompts such patriotism,** and you will get replies which will have some bearing on his character. He may be an adventurer, or out of a livelihood, or he may have a genuine desire to fight for the "Allied" cause.

Give careful attention to sub-paragraphs 3, 4 and 5 of paragraph under caption "Five Sorts of Dangerous Persons".

14. In cases of ranks bearing distinctly foreign names, especial attention should be paid to the antecedents of such.

15. Examining officers remarks on each individual must be noted after examination is made.



CHAPTER I.

Map Reading

An officer or man cannot be considered as being fully proficient in military map reading until he can by a close study of a Standard Ordnance Map see in imagination all the features and detail of the country portrayed.

Formerly maps varied greatly in design, size and style of production, and in the manner they showed the details of a country, but the last year or two has brought them more to a standard type, and certain conventional signs are now only used to show certain detail; even with these new ideas in map printing, they have their limitations, and should never be considered a complete substitute for the actual examination of the country itself.

Dependence on active service will naturally have to be placed on maps of small scale, according to the amount of territory under consideration. The smaller the scale, the less amount of detail there will be shown, and in many of the best large scale maps, valuable military information as to the detail of the ground, such as under-features, ditches, small culverts, etc., could not be shown for lack of space. Speaking generally, the average map is more lacking in the actual form or lay of a country than they are in the details of the roads, rivers, hedges, railroads, etc.

Expense of close contouring makes it almost out of the question, and it is seldom that you get a 6-inch map contoured at 20-foot intervals. Even with a map contoured at 20-foot intervals, such a map could not be depended on without an actual visit over the ground to decide exactly where you would place a firing line, or place a line of trenches, as it would not show sufficiently well what con-

cealment the ground in front of your line might afford the enemy. The vertical intervals being at 20 feet, under-features of less than 20 feet would not appear on this map.

This rule applies particularly in a gently rolling or undulating country, in sunken roads, etc. A map will have to be considered as an aid to, and not a substitute for, an actual study of the ground that is under consideration.

On opening up a map, look at once for the scale; this gives you a key to the distances and extent of country that the map takes in. Then carefully examine the contours or other means used to show the form of ground. Contoured maps are by far the most successful for military purposes, and a close study should be made of the vertical interval used, also of the spot levels, if any, which may indicate important underfeatures, or high points.

Some maps formerly only showed spot levels, which were found along the high roads, on the heights, along railroads, in villages, etc., and had a system of shading or hachures to help denote the valleys and water courses, but the modern map will always be and is contoured, as this is the only positive method of showing properly the lay of any district, either flat or mountainous.

Plates for Examination

Plate 3. Shows contours, vertical hachuring and and spot levels.

Plate 4. Shows map with contours, and squared surface.

Plate 5. Shows a German map of the older military type.

Plate 2. Shows French trench map, with spot levels and scale in meters.

On older maps where contouring has not been printed, much assistance can be given to rapid reading by coloring in the streams with a blue

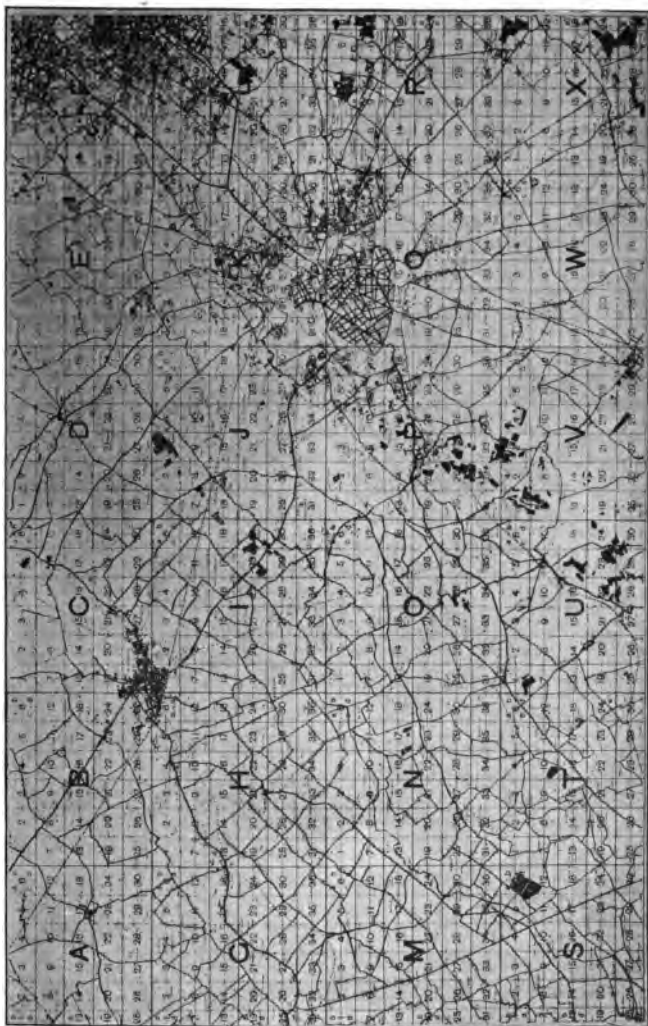

FRENCH MILITARY MAP

pencil or ink. This will show up the valleys and give the map a much more natural appearance.

True and Magnetic North

The direction of true or of magnetic north on a map is of the greatest importance. In all descriptions and orders issued with reference to any military map, the points of the compass, stated in **degrees**, are used to express the direction of one object from another.

On a map where the north and south meridians are not shown, and there is no map "Grid" the north pointer or compass "Rose" will have to be used for the purpose of setting, and it will save time and errors to draw on the face of the map a few lines parallel with the north pointer to enable bearings to be arrived at anywhere on the map with convenience.

In quoting a bearing in reports and messages, only the **true bearing** is used and all magnetic bearings must be reduced to true bearings before they are sent in. All compasses have personal error and unless this idea is followed out to the letter, it would be impossible for one man to use another man's bearing unless he sent the compass along with the report; two different compasses would give entirely different courses owing to their personal error.

Setting a Map

A map is said to be "set" when it is laid out on the ground or some other flat surface, so the true north on the map points to the north pole. If distant objects that can be seen in the country are compared with the same objects on the map, they will be found to bear the same "bearing" or direction from the observer.

A Map May Be Set in Several Ways

1. With a Compass.

This is the surest and most satisfactory way. Lay the compass down on the map, with the top

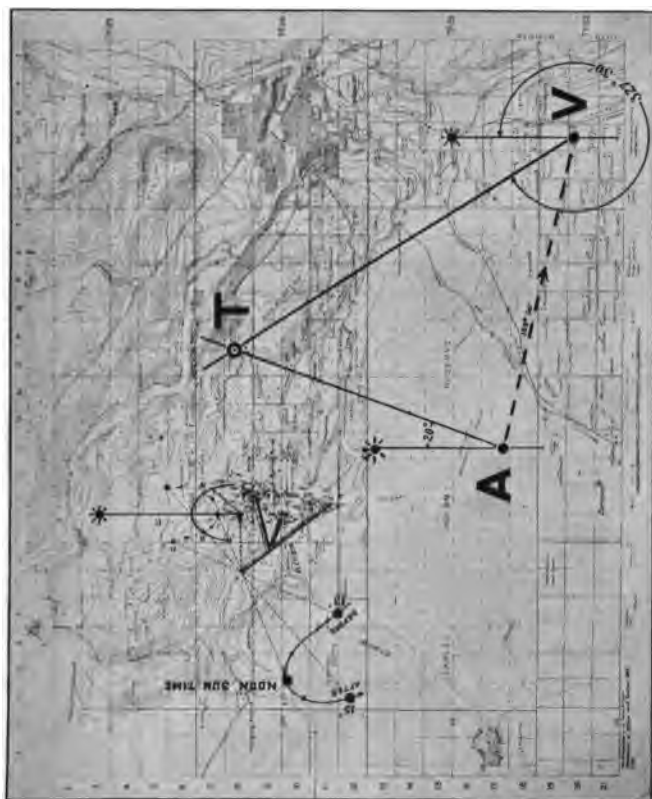

CANADIAN TRAINING MAP

lid folded back to an angle of 180 degrees, placing the small nick in the ring of the compass and the nick in the top lug on the cover, along the same north and south line, the zero, or 360-degree mark on the compass dial to be towards the north, and without disturbing the compass slowly turn the map around by grasping it by the edges until the compass needle registers the correct variation east or west from the true north point. **Remember that it is always necessary to make the allowance for magnetic variation when setting by a compass, consequently the north and south line on the map has to make an angle equal to the variation, with the needle point of the compass, before the map is set true north.**

2. By Objects.

A map can be set by objects on the ground without the use of the north point or a compass.

- (a) **When you can identify your position on the map.** Identify your position on the ground and find the same point marked on the map. Also locate on the map some object that you can see in the distance, such as a church, house, bridge or smokestack. Join these two objects together by laying a rule or drawing a pencil line through them, then turn the map until your position on the ground and the distant object are in line with the line you have drawn on the map.
- (b) **When you do not know your exact position.** Place yourself between or in prolongation of a line joining any two points which can be identified. Turn the map until the line joining the two points on the map points towards the two positions selected in the country. The map is then set approximately.

GERMANY

11

12

B

B

C

C

D

D

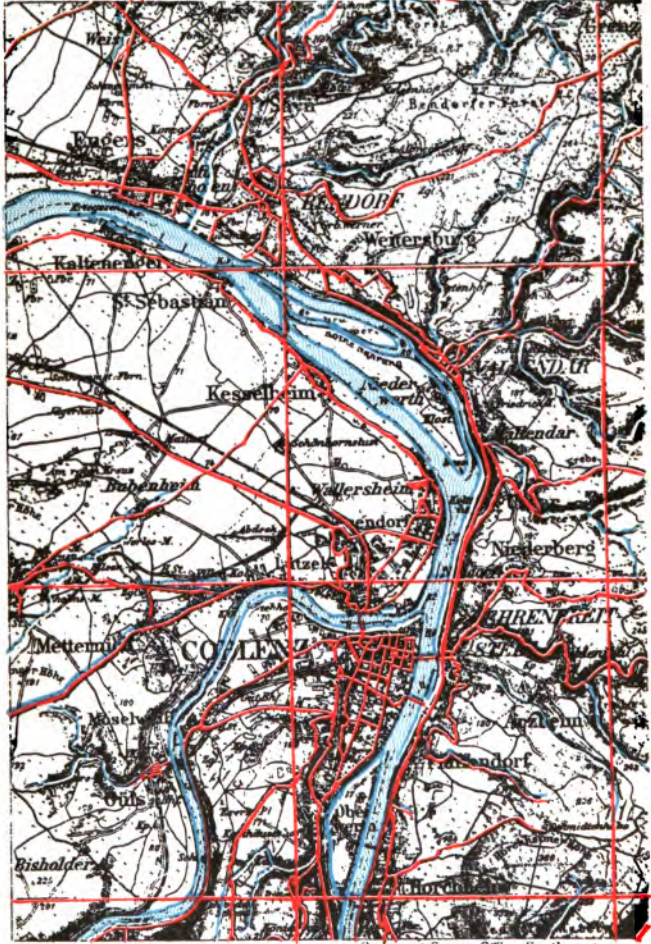

Ordnance Survey Office, Southampton

Scale 1:50,000 1:50 Miles to 1 in

Miles Miles

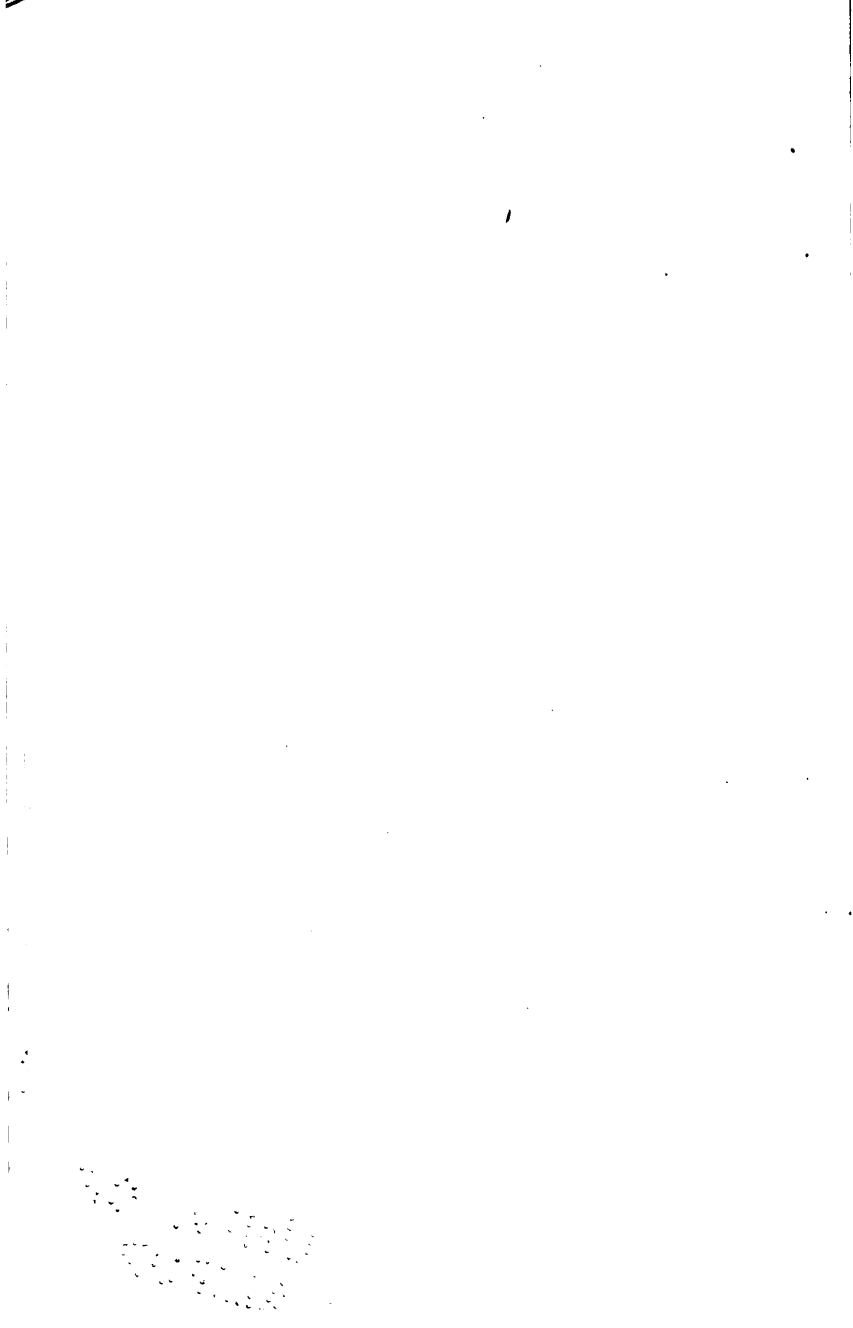

**ENGLISH ARTILLERY TRAINING MAP**

Data Procured in the field by the Intelligence Section after four months training

A map may also be set approximately for reading by identifying on the map several prominent objects that can be seen by the observer or by the observer standing by some straight feature marked on the map like a straight road, railway, river or canal, the map being held so that the same road on the map is parallel with the real road, river or other feature.

Scales on Military Maps

A Scale Shows the Proportion that the Distance Between Two Points on a Map Bears to the Distance Between the Same Two Points on the Ground.

The scale of a map may be shown in three ways:

(a) **By a statement in words**, such as "4 inches equal 1 mile" or "1 inch equals 1 mile."

(b) **By a representative fraction**—such as $\frac{1}{63360}$

which means that 1 inch the upper figure, called the numerator, represents on the map an equal distance to the lower figures, 63360, called the denominator, does on the actual ground. Or in other words, the map with a representative fraction like the above would have a scale of 1 inch to the mile.

When a map has a representative fraction to denote the scale, it does not follow that the representative fraction must be in inches; it may be in inches, yards, feet or meters. The representative fraction means that one unit on the map represent a certain number of the same units on the ground.

(c) **By a scale divided into parts**, each part being a unit of a certain length, which is stated below the line called the scale line.

PLATE NO. 6

Scale No. 1

Scale $\frac{1}{15840}$, or 4 Inches to 1 Mile.



500 1000 1500 Yards.

Scale No. 2

Scale $\frac{1}{31680}$, or 2 Inches to 1 Mile.



1000 2000 3000 4000 Yards.

Scale No. 3

Scale $\frac{1}{100000}$, or 1 Inch to 1.58 Miles.



1 2 3 4 5 6 7 8 9
Miles.

Scale No. 4

Scale $\frac{1}{126720}$, or 1 Inch to 2 Miles.



1 2 3 4
Hours.

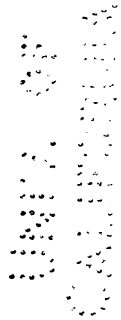

In working examples and in the construction of scales by keeping in mind the fact that 63360 inches equals 1 mile, a great deal of assistance will be afforded.

To find the number of English miles to the inch for any military map that has a representative fraction divide the denominator of the representative fraction by 63360; this gives the number required;

if the representative fraction is $\frac{1}{80000}$ then the number of miles to the inch equals $\frac{80000}{63360}$ equals

1.26.

To find the number of inches to the mile, divide 63360 by the denominator of the representative fraction. If the representative fraction is $\frac{1}{80000}$ then the number of inches to the mile equals

$$\frac{63360}{80000} = 0.79.$$

The measure of length which a scale line is to show, no matter what units the scale is made in (inches, feet, yards or miles), is called the "unit of measure" and scales are usually, though not necessarily, constructed of such a length as to represent a distance which is a multiple of ten such units, as 500 feet, 1,000 yards or 20 miles.

A scale should be made from 4 to 6 inches long, as this is the most convenient length to use on the average map, when you have decided on the length of line you are going to use, it is then a matter of calculation as to the number of units you wish to divide into this certain length of line. On the other hand if you have a certain number of units that you wish to use in the scale, then it is

a matter of calculation to arrive at the correct length of line.

The size of scale used for field sketches depends entirely for what purpose the sketch is going to be used, and the amount of topographical information the sketch should show to serve its purpose.

Reconnaissance sketches of an area of ground to explain a plan of attack, or to show the lines an attack is to be made on, a road or river, line of trenches, an outpost position, etc., which cover considerable country, are usually made on scales ranging from 1 to 4 inches to the mile. Sketches which are intended to show the detail for defense of a village or town, or for camp or billeting areas, are much more satisfactory on a scale of 4 to 6 inches to the mile, and local sketch plans of trenches or a battalion's particular movement where a larger scale yet would be required to show each part of the detail of say a trench raid, should be made on a scale of 12 inches to the mile, or larger.

Information re foreign measurements:—

- (a) **Used on French, German and Belgian maps.**
- | | |
|-----------------|----------------------------|
| 100 centimeters | = 1 meter. |
| 1,000 meters | = 1 kilometer. |
| 1 meter | = 39.37 inches. |
| 1 kilometer | = 1,093.63 yards. |
| 8 kilometers | = 5 miles (approximately). |
| 10 meters | = 11 yards. |
- (b) **1 Russian verst = 3.500 feet or 1.167 yards.**

Explanation of Plate on Scales.

Scale No. 1. To construct a scale of 1 inch to 1 mile to show miles and quarters of a mile.

A line 6 inches long will represent 6 miles, divide this into inches and the left division into quarters, which will each represent one quarter of a mile.

Scale No. 2. To construct a scale of 2 inches to 1 mile to show hundredths of yards.

In this case 5,000 yards, being an even number, and nearly 3 miles, will clearly be represented by a length of line of about 6 inches, now we first require the representative fraction and afterwards the exact length of line to use.

$$\text{The representative fraction} = \frac{2 \text{ inches}}{1 \text{ mile}} =$$

$$\frac{2 \text{ inches}}{1.760 \times 36 \text{ inches}} = \frac{1}{31.680}.$$

Then 5,000 yards

will be represented by $\frac{5,000 \times 36}{31.680}$ inches or 5.68

inches. Draw a line 5.68 inches long. Divide this into five equal parts (each part would be 1.14 inches long). Subdivide the left hand division into 10 equal parts, each 0.11 inch long; each of these small divisions will represent 100 yards.

Scale No. 3. To construct a scale of $\frac{1}{100,000}$ to show miles.

Here 1 inch on the map is represented by 100,000 inches on the ground.

One mile would therefore be $\frac{63360}{100,000} = 0.634$ inch.

If your completed scale represented 10 miles, it will be 6.34 inches long, each mile will be 0.63 inch long, and if the left hand division is divided into fourths to show quarters of a mile, each of these small divisions will be 0.16 inch long.

In military operations distances are sometimes measured by the time required to traverse them, and in this case the linear scale may be usefully supplemented by a scale of hours.

Scale No. 4. To construct a scale of time for a column of troops marching at the rate of 3 miles per hour.

Taking the scale of the map as 1 inch to 2 miles, this would give representative fraction =

$$\frac{1}{63.360 \times 2} = \frac{1}{126.720}$$

If the scale be made 6 inches long, it will represent 12 miles, i. e., the distance marched in four hours. Divide this into four parts and each will represent an hour's march. By dividing the left section or division into 12 parts, each will show the distance marched in five minutes.

Note. Before closing this short sketch on the construction of scales, a word or two regarding the importance of being able to fully understand the principle and construction of them, might not be out of place.

A great many instructors waste entirely too much time teaching the average man to construct and work scales; if they would confine their efforts more to teaching the men the practical use of the scales printed on all modern military maps (i. e., the divided line scale, the representative fraction and the 1,000-yard squared system) there will never be any difficulty in their getting full use of their maps.

In making field sketches and other work where they have to supply their own scale they soon get into the habit of using the standard inch measurements. The simpler this subject can be made the more efficient every man will be in map reading.

Methods of Representing Hill Features

There are four systems of representing hill features, all of them more or less satisfactory, but as some standard system is the idea on which all military authorities are at the present time work-

ing, the contour seems to be the most satisfactory and general in use in military map work.

The four systems already mentioned are:—

1st. **Contours or approximate contours** called "form lines".

2nd. **Contours with hachuring** or shading on slopes, etc.

3rd. **Hachuring alone.**

4th. **By the shaded layer system**, each V. I. raise having a slightly different shade of color.

Contours show hill features with exactness, and fully answer the purpose on a map, that is required; they are also the means by which all up-to-date maps show hill features. **To reproduce exact contour lines on a map** is a rather expensive operation, but approximate contours or as commonly called "form lines", can be reproduced by the ordinary man on a field sketch, after a few weeks' instruction and actual field practice, and give a very fair idea of the country that the sketch represents.

Contour lines on the ordinary service map are in fine red or black lines, and do not in any way interfere or obscure the other important detail, such as hedges, roads, railways, etc., which are also shown by black lines; another thing about them is that there is very little danger of confusing the contour lines with those of conventional signs.

Sketches of trenches and local country can very readily be filled in with form lines at any convenient vertical interval, so as to show in more detail any local dips or rolls in the country which would enable the officer in charge of operations to figure out where dead ground would occur, or what would be a probable site for a line of trenches. Without these approximate form lines the sketch would convey no idea of the lay of the country.

If a map shows contours close together, the slope at that point is steeper than in a place where

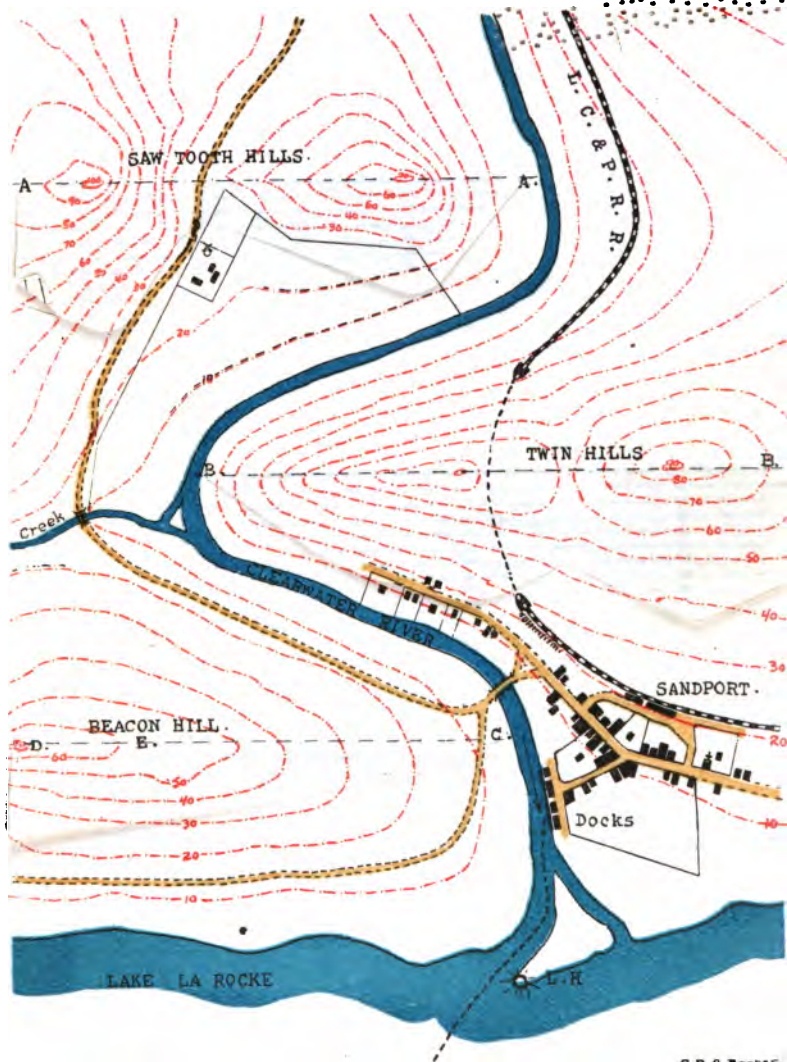

TO THE
MEMBERS OF THE
COMMISSION ON
THE STATUS OF
WOMEN

the contours appear further apart. By examining plate you will notice that from point C to D the contours are very close to one another; on the other hand, from the points C to E the contours are much further apart. By turning up the flap in the map, a cross section of the hill, cutting through the above points, will be had, when the exact slopes are plainly shown.

This same cross section of the hill will clearly show how the contours are represented in the flat map of a country. Take the section from A to A in plate No. 8, by examining the contour lines on the map they plainly show that there are two hills with a valley between, the road shown on the map at this point passes between. By again turning up the flap, an exact outline in section is shown of the country from the point A to A.

In plate No. 8 the contours are shown as being 10 feet apart in vertical interval; that is, the water is taken as the datum level. The first red line which runs up along the river, at a varying distance from the water, is marked with the figure 10. **This means that all along this red line the land is just 10 feet higher than the water level.** Then the figure 20 is on the second line from the water, which means that **this line wherever it goes, is 20 feet above the water level,** and so on until the highest point on the map is reached by a small red circle in the upper left hand corner, marked 100; in other words this is the highest point on the map, with an elevation of 100 feet above the water level.

Take as an example the entrances to the tunnel shown, in which the railroad passes through the **twin hills.** By looking at the map you find this tunnel cuts into the hill at the contour marked 30. You would at once understand that the tunnel was 30 feet above water level and by again turning up the flap of the map at this point, you will have a

sectional view of this hill, showing where the tunnel passes through, and showing the distance above the water or datum level.

One of the plainest and simplest means of showing a new class how contours are used to show slopes, hollows and general features of the country, is by means of an old umbrella (see sketch). Take and open this umbrella, then by holding the top on a table, have one of the men slowly turn the umbrella by the handle, at the same time taking

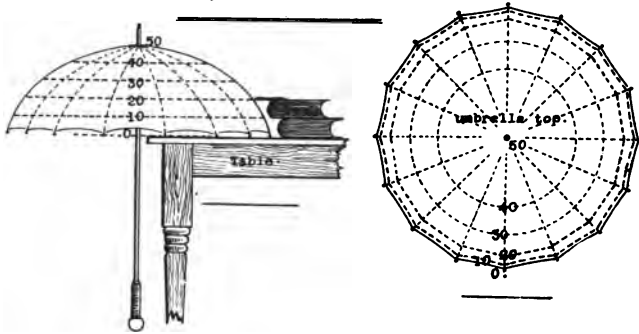

a book of say 2 inches thick as a rest, and with a piece of chalk draw a line around the outside of the umbrella top, calling this contour 10; then put another book 2 inches thick on top of the first one and projecting another line onto the top, getting contour 20, and continue until the top is finished, making a low, flat hill with convex sides. It is then easy to explain by showing them the top in plan and elevation, how contours are arrived at, and what they mean.

Conventional Signs.

The characters or symbols used on military maps to represent the different details are called conven-

tional signs, and the reason for the use of such signs or symbols, is mainly because it would be impossible to print into the face of the map all the desired information through want of space. Consequently some simple method of representing the different features was devised.

These signs are simple in character, so that they may be easily remembered and understood, and are made as standard in design as possible, all class and text books showing practically the same cuts and plates representing them. New symbols should never be used, unless they are authorized by headquarters; should you desire to show or represent some feature for which there is no conventional sign, it is much surer to write a note, bearing on that point in the margin of the sketch or map.

Plate No. 9 shows the conventional signs approved. These signs should be carefully studied and committed to memory, and in making field sketches used to show the different features they represent.

A road as shown is drawn with continuous black lines at the sides, when a ditch, fence or other obstacle of any kind prevents men or transports from moving off same. The coloring represents the paving or metalling of the road; if colors are not available when making sketch, the words "MET-ALED" or "UNMETALED" should be written along the roadway, thus showing what class of road you are showing.

The width of a road paving or metaling should always be given; a road with 14 feet or more pavement will handle two lines of traffic, and it is a very important bit of information to have on a sketch. The width of a road should be printed across the pavement or metalling by simply marking the number of feet, i. e., 14 feet or 8 feet, etc.

A railway was formerly shown on service maps by a "continuous thick black line with cross bars, and the word 'single' or 'double' printed along the line". In more modern ordnance maps the railways are being shown by two black lines filled between with even black and white spaces, as shown in Plate No. 4. In the case of a double track, another line of tracks is shown alongside.

Where a main road or railway runs into the margin, or off a map, the name of the nearest important town is printed in the margin just at the end of your track. The distance from the end of the line, as shown, to this town is also stated in miles, i. e., YOUNGTON, 4 miles.

Contours or form lines are drawn in brown or red, and may be done in continuous lines or in dotted lines. As most men find one way much handier than the other, in putting contours or form lines on a sketch care must be taken to get the elevations properly numbered and see that all the contour lines "jib" or have a correct reference to one another.

Cultivation is indicated by writing in the enclosure of fences or hedges the nature of the crop, its height, what cover it would afford, obstacles it would afford, etc., according to what service the sketch is desired for.







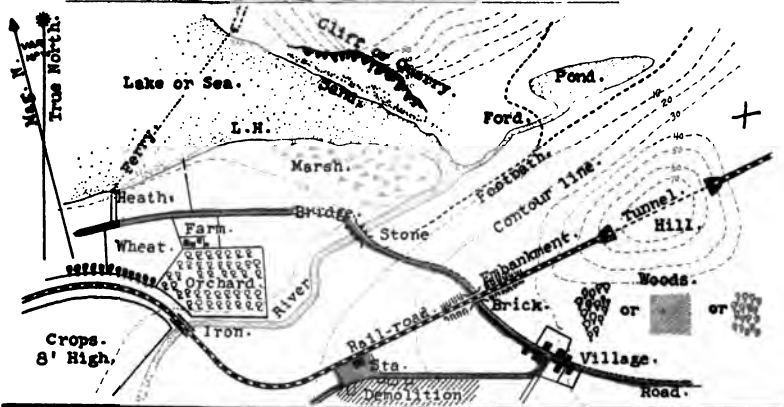

















A river should be drawn in blue, but black lines can be used to good advantage where blue is not available. Rivers, ponds and lakes should all have their names printed along their course, with the direction of the current indicated by an arrow. Where the width, depth, nature of the bottom and banks, fords, bridges, etc., are desired, the conventional signs should be used, but where no sign is available to represent the information, a note should be put in the margin fully explaining the point in question.









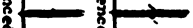
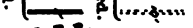

The material a bridge is constructed with, is shown by printing alongside the sign of a bridge the word iron, stone, wood or brick, as the case

CONVENTIONAL SIGNS & TERMS USED IN MILITARY TOPOGRAPHY.



CHURCH or CHAPEL.

- With Tower. 
- With Spire. 
- Without Tower or Spire. 
- Windmill. 
- Obstacles. 
- Post Office. 
- Telegraph Office. 
- Telephone Office. 
- Sign Post. 
- Well. 
- Telegraph Line. 
- Entrenchments. 
- Mounted Troops. 
- In Line. 
- Column of Route. 
- Yedette. 
- ARTILLERY.
- In action. 
- On march. 
- INFANTRY.
- In Line. 
- Column of route. 
- Other formations. 
- Sentry. 
- TRANSPORT. On march. 
- Parked, 

- 1st. Class Roads 
- 2nd. Class Roads. 
- 3rd. Class Roads. 
- Railroad. 
- Tramway (trench Etc), 
- Canal. 
- Wind-pump. 
- Trig. Sta. & Alt. 
- Spot Level. 
- Contours. 
- R.R. Cutting. 
- Bridle or Footpath. 
- Name of town, Village, River Etc. **YOUNGTON.**

may be. Other information such as width, length, number of spans, as to the probable strength of the bridge, etc., can be stated in a note near the bridge or in the margin.

Heath, heather or marsh or swamp should be shown by the word printed in black on the spot where this feature occurs; the nature of the feature should also be stated. Some marshes have a good bottom and a body of troops could with only a wading pass across them, so these details have to be investigated and written in the form of a note on the sketch or in the margin.

In woods or timbers the class of timber should be stated, i. e., spruce, pine, fir, poplar or oak, and as to their passability for the particular arm of the service the sketch is being used for. It is also a good point to state if the woods afford much cover for an enemy.

Water. Always indicate on a sketch or map the points at which good water can be had for men and horses or other live stock.

Troops. There are times when the positions of troops are to be shown on sketches and maps. For this reason conventional signs to indicate them have been approved of. In showing the enemy, blue is used, and showing your own position red, the same conventional signs being used in both cases. The strength and unit represented should be written near the conventional sign, when this information is desired.

In sketches for placing outposts, pickets, reserves, etc., it is the general thing to use a capital letter to indicate where and what a small body consists of, i. e., Outpost—P; Picket—P; Reserves—R; Patrol—P, with an arrow showing the direction they are moving in.

Lettering on sketches should always be in a clear, neat print. The words should be placed so there will be no confusion as to what they indicate. Names of towns, villages, cities, rivers and hills,

etc., should be made in plain black CAPITAL LETTERS.

All the lettering should be horizontal with paper, the exceptions being in the case of rivers, railways, canals and roads where the names should be parallel to the feature being described. In describing the nature of a certain piece of country or district, the words pertaining should be written on that particular spot on the sketch or map, care always being taken not to destroy the general usefulness of the sketch in writing in these notes.

Map Reading

Topographical Definitions

Basin.

A term used to describe (a), a small area of level ground surrounded or nearly surrounded by hills; and (b) a district drained by a river and its tributaries.

Bluff.

Cut Bank—slide of earth in face of hill leaving an exposed face of earth.

Col.

A depression between two adjacent mountains or hills, or a break or dip in a ridge line.

Crest.

The edge of the top of a hill or mountain, the point at which a gentle slope changes to an abrupt one; the top of a bluff or cliff.

Escarpment.

An extended line of cliffs or bluffs.

Gorge.

A rugged and deep ravine.

Knoll.

A low detached hill.

Nullah or Donga.

The dried up bed of a river or stream.

Plateau.

A flat surface on the top of a hill; an elevated plain.

Re-Entrant.

A valley or depression running into the main feature.

Ravine.

A narrow valley with steep sides.

Saddle.

Same as a Col.

Slope.

A down or up grade; side of a hill slopes.

Spur.

A projection from the side of a hill or mountain running out from the main feature.

Salient.

A projection from the side of a hill or mountain, running out and down from the main feature.

Tableland.

A high-lying level district of country.

Underfeature.

A minor feature; an offspring of the main feature.

Undulating ground.

Ground consisting of alternate gentle elevations and depressions.

Watershed.

A ridge of high land separating two drainage basins, the summit of land from which water divides and flows two ways.

Watercourse.

The line defining the lowest part of a valley, whether occupied by a stream or not.

Quarry.

A mine or pit, from which stone or other material has been excavated.

Technical Definitions.

Angle.

Is the difference quoted in degrees between two bearings; i. e., the angle of a true north bearing and a northeast bearing, is 45 degrees.

Base or Base-Line.

A carefully and accurately measured line upon which a triangulation depends.

Bearing.

Is the direction of any object from the observer, measured by the number of degrees from the true north (after corrections have been made for the variation of the compass). In every case the angle is always measured from north by east and south, or the same way the hands of a watch revolve.

Bench Mark.

A stone placed to mark a level accurately fixed by instruments.

Contour.

A contour is the representation on a map of an imaginary line running along the surface of the ground at the same height above mean sea level throughout its length.

Datum.

Or Datum Level is an assumed level with reference to which heights are measured, or compared. In most cases sea level is used.

Dead Ground.

Ground in which the observer could not see the desired object.

Defile.

A portion of the route where troops have to reduce their frontage in order to pass, e. g., a mountain pass, bridge, an embankment, an archway or gate.

Fall.

The drop in elevation of a river during its course, usually measured in feet per mile; 2 feet per mile fall.

Form Lines.

Approximate contours sketched in by hand and eye work.

Gradient.

A slope expressed by a fraction. $1/30$ represents a rise or fall of 1 foot in 30 feet.

Hachures.

Are short, disconnected strokes of the pen, by which shading of hill features may be effected; the strokes are drawn directly down the slopes.

Horizontal Equivalent (H. E.).

Is the distance in plan horizontally between two adjacent contours.

Intersection.

Is the term applied to a certain class of military sketch, where the work is only approximately correct.

Magnetic Meridian.

A magnetic north and south line.

Meridian.

A true north and south line.

Local Magnetic Attraction.

The deviation of the magnetic needle of a compass from its mean position owing to the presence of masses of magnetic iron ore, railway tracks, or other bodies of iron which affect it.

Magnetic Variation.

The angle between the true north and the magnetic north. This angle varies slightly from year to year all over the world. It is called east or west variation, according as the needle of the compass points east or west of the true north.

Orientation.

Or **setting** a map or sketch is the process of placing the map or sketch so that the north line or compass pointer on the map points to the north point of the globe.

Plotting.

The process of laying down on paper field observations and measurements.

Profile.

The cross section of a piece of country, hill or other feature, a hill cut through on a vertical plane.

Ray.

A line drawn to represent the direction of an object without reference to the points of the compass.

Re-section.

A method by which the sketcher determines his position by observing the bearings of, or drawing lines from, at least two previously fixed points.

Scale.

The word scale is used to denote the proportion which a distance between any two points on a sketch or plan or map bears to the horizontal distance between the same two points on the ground.

Section.

Same as profile.

Spot Level.

The record on a map, shown in figures, of the exact height of that particular spot.

Triangulation.

The process of fixing the position of a point or points on the area to be surveyed, by means of a measured base and system of bearings taken from stations on that base.

Traverse.

The survey of a road, river or piece of country by taking a series of compass bearings with the distances between each turning point, or station, and noting the information enroute.

Vertical Interval.

Sometimes written V. I., and always given in feet, is the difference of level between two adjacent contours.

Traversing.

Getting the "lay" or shape of a piece of country or road, by taking a series of measured straight lines, with a compass to give directions, and a tape or pacing to get the measurements, is called traversing.

The straight lines C-C-C-C in Plate No. 10-B are called Traversing lines, and the measurements must be taken exactly along these lines from station to station, in order to make the plot or sketch correspond to the actual country or road.

After the bearing of a traverse line has been taken and noted down in the field book, and while the man making the sketch is actually walking along the traverse line making his measurements, he locates any information required along the traverse line, as he comes abreast or at right angles to it by means of cross bearings, or offsets. It entirely depends on how far on either side of the traverse line this information should be taken note of, but about 100 to 150 yards as a rule answers all purposes.

Traversing is very useful for many purposes, and should be well understood and practiced by every man in the intelligence section. Should the officer in charge of operations require a sketch of a new section of trenches, where men could not walk on the surface of the ground, their only way of securing an accurate sketch with the necessary measurements is by the means of a traverse. This rule holds good in any enclosed country where the view is limited, making it impossible to see to any distance, and establishing positions

by intersections of "bearings" taken on objects in the distance.

The field book is not a special book, as any ordinary good note book can be used for this purpose. All that is necessary to do in making it suitable for **traversing** is to rule down the center of the page two lines about 1 inch apart; this forms what is called the "chain column". You enter in this column all the forward bearings taken with the compass, and also the forward measurements. At both sides of the "chain column" are entered the various items of information secured as the sketcher proceeds along the route being traversed.

At every station or turning point in the traverse line, a line should be drawn across the chain column, which shows at once that a turn has been made at that point. Each station is there marked by putting either a capital letter A, B, C, D, etc., or by the figures 1, 2, 3, 4, etc., enclosed in a circle, showing the number of that station, i. e., (A), (B), or ① ② ③ ④ (Plate No. 10-A).

In Plate No. 10-A, we have a sample page of a field book after the traverse has been made and all the desired notes are completed ready to plot on arriving at headquarters or camp. The lines A-A are the two ruled lines to form the chain column, and while they are about 1 inch apart, they really represent the center line of the traverse, split in two in order to leave room for the bearings and measurements to be placed in order as they are secured.

In checking this simple traverse up, shown in Plate No. 10-A, you find that the man started at station ① He took his first bearings as far as he could see along the road, which was 72 degrees; he then made a note of the road to his right, and marked it down in the space to the **right** of his chain column (to Sumas W. 10 miles); he also made a note of its bearing (170 degrees). To the

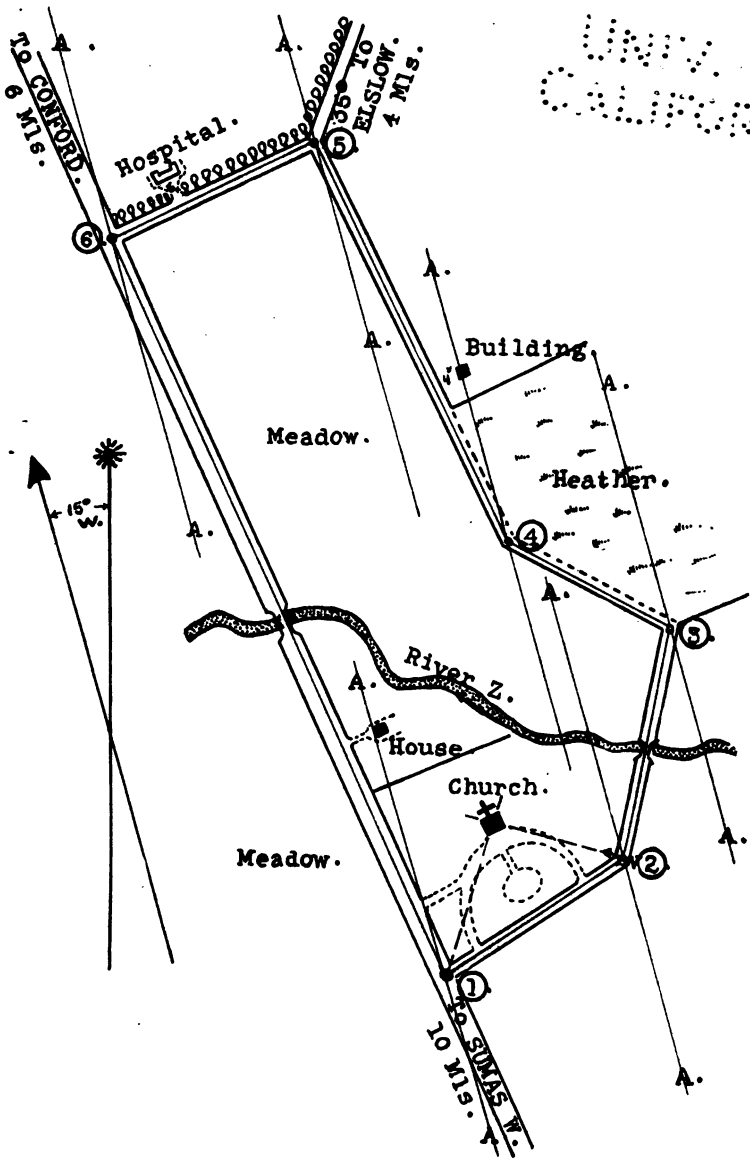

Handwritten text in the top right corner, possibly a name or title, rendered in a dotted or stencil-like font.

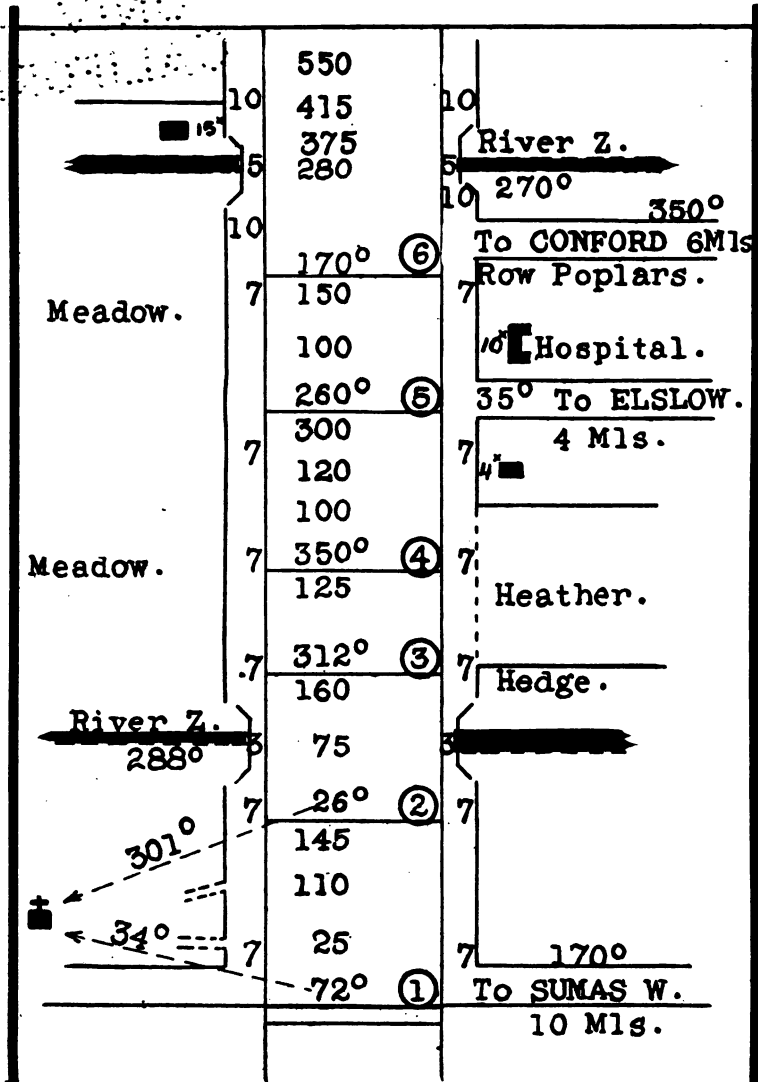

left at some distance was a church, which he noted by taking a "cross bearing" on the tower (34 degrees). He also noted the road width to right and left, as being 7 yards and 7 yards, consequently he was standing in the center of the road when he took his bearing for his first traverse.

He then proceeded to pace up the first traverse line, and after going 25 paces came to a roadway turning in at the left; as this was into a private property, he dotted it into the edge of his sketch, and then taking up the count of his pacing at 25, went on until he arrived at another road turning in on the left at 110 paces. After stopping and making a note of this road, he again took up the count at 110 and after pacing until he came to 145 paces, he arrived at the turn in the road, and the end of his first bearing.

Stopping here, he drew a line across his chain column, which showed that he had finished that traverse, then started a new one by marking down the number ② and taking a bearing up the new piece of road, which gave him 26 degrees; as he was still in the center of the road and it still was of the same width he marked down 7 yards on either side of the chain column. He also took another bearing on the church tower to the left (301 degrees).

After starting from station ③ he paced 75 paces when he came to a bridge over the river Z. As this bridge was not as wide as the road he drew in the sides somewhat closer to the chain column than the hedges had been shown, and also marked in the width as being 3 yards on both sides. He must have crossed this bridge in the center as the total width would be 6 yards according to these figures. He also noted the direction the river was flowing and put an arrow to indicate same, taking a bearing down stream (288 degrees) for future use in plotting the field notes. Taking up the

pacing at 75 he proceeded until at 160 paces he came to another turn in the road, and closed this traverse in his field book by again drawing another line across the chain column.

He started the next traverse by marking the number of the station ③, then taking his forward bearing (312 degrees) and marking in the width of the road to either side which is still 7 yards and 7 yards.

Up to this point there has been a hedge or other obstruction running along either side, and he has drawn a solid black line along both sides of the chain column, broken only where he crossed the bridge, as the bridge was somewhat narrower than the road. Now at station ③ on the right of the chain column, you will notice that he has turned this line off at right angles, drawing it to the right and toward the outside of the page. He marked it **hedge**. From this point the right line is dotted, meaning there is no obstruction to moving off the road until above station ③.

After pacing 125 paces he comes to another turn in the road and again draws a line across the chain column.

Starting the new traverse with the figure ④, he takes the bearing 350 degrees, notes the width of the road as being 7 yards on either side, and makes further notes of the ground being covered with **heather** to the right and a **meadow** to the left, and proceeds to pace up the new traverse. At 100 paces the hedge again comes out to the road, as shown by the black line on the right, and at 120 paces there is a house in the right hand field which is 4 yards inside the hedge, as noted by Fig. 4*. Continuing on until 300 paces has been reached, he comes to a fork in the road, and closes this traverse by the usual line.

Noting down ⑤ for the new station, he takes the bearing along the new traverse (260 degrees)

and draws in on the right a road (to **Elslow** 4 miles) and noted the bearing of this road (35 degrees); then starts his pacing and at 100 paces comes abreast of a large building on the right, which is 10 yards inside the hedge. He finds out this is a **hospital** and marks it as such; he then goes on until at 150 paces comes to the end of the traverse, and draws a line across.

At station ③, he gets a bearing of 170 degrees for the next traverse, makes a note of the road bearing 350 degrees (to **Conford** 6 miles); also to the fact that there was a row of poplars running along the last traverse, and that there is a **meadow** to the left. In noting down the width of the road he finds that it now measures 20 yards, and as he is in the center, puts 10 on either side of his chain column.

After pacing along this new traverse for 280 yards, he comes again to the river, Z, which is flowing from left to right, indicating the direction by an arrow. The bridge measures 10 yards wide, so notes 5 yards on either side, being in the middle of the bridge. He then goes on, and at 375 paces makes a note of the house to the left, which stands 15 yards inside the hedge. At 415 yards there is a hedge running away at right angles to the left hand side of the road, and at 550 paces he comes to the station No. ④, completing what is called a "closed traverse".

There is no scale used in connections with the field note book. The chain column is simply used to put the information down in a proper sequence, so when they are being read off for plotting there will be less likelihood of making any mistakes.

Plotting the Traverse from the Field Book

The first thing to do towards plotting on the drafting paper is to establish a magnetic line to work from. At station ①, plate No. 10-B, you will

MILITARY MAP READING

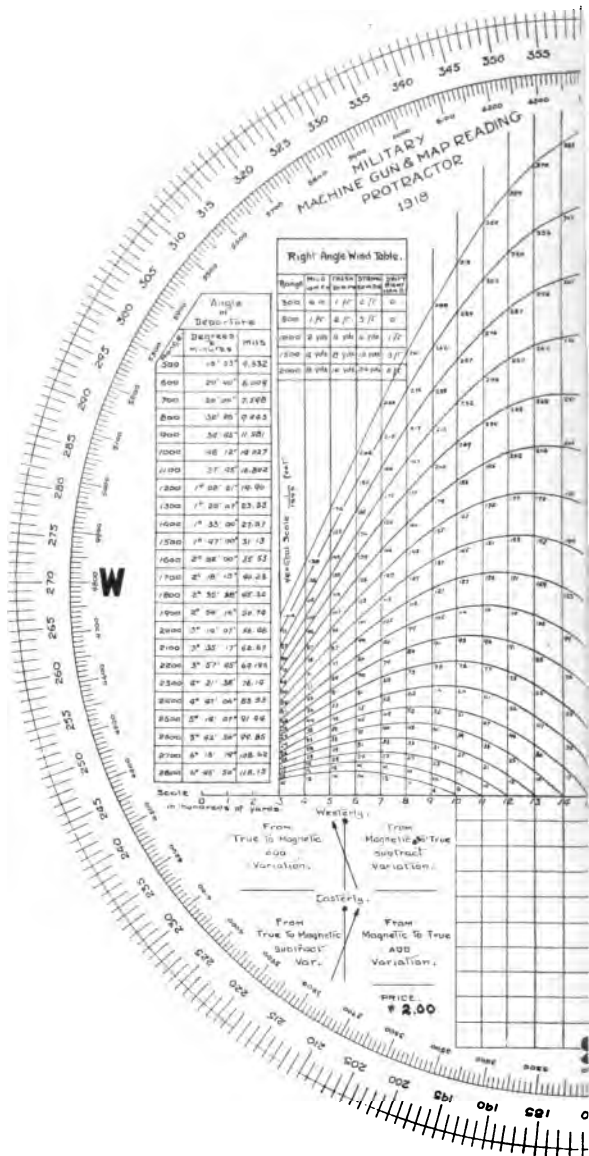

notice a light red line, A-A. This is the magnetic meridian, or line from which you turn off the bearing 72 degrees. After setting off this bearing by means of a protractor, draw in your traverse line, and along this line measure off 145 yards, using the scale desired. At the 145-yard point, mark in station No. ① and establish another magnetic line which must be parallel to the one already at station . From this second magnetic meridian you turn off your next bearing 26 degrees; then proceed to draw in your traverse line and measure off along this line the 160 yards to your next station, No. ③. As each station is arrived at a new magnetic meridian is drawn in, parallel with the previous ones, and this process is repeated until the complete plot is finished.

These magnetic meridians may be drawn in any direction on the sheet of paper, but in starting the plotting of a traverse, care should be taken that there will be room on the sheet of paper to complete the drawing. This, however, is a minor point, and a little practical work on traversing and plotting will soon make things clear to the beginner.

After the sketch has been plotted with all the different information put in at the proper places, as noted in the field book, the magnetic meridians should be erased, as they have nothing to do with the completed sketch, and are merely used for laying off the different bearings. In plate No. 10-B the magnetic meridians have been purposely left in and lettered to show how they should be worked from.

In plate No. 10-B it will be noticed that the magnetic north pointer is parallel with the red magnetic lines. Now to establish the true north, all that is necessary to do is to take the protractor and set off from this magnetic pointer another pointer with the proper number of degrees difference. In the case of the plot in plate No. 10-B, the differ-

ence was 15 degrees west, so we made the north pointer to the right of the magnetic pointer. The magnetic lines were drawn off a true upright line to make allowance for this variation of the compass, and when the sketch or plot was finished it lay on the paper in about the correct manner of map making, i. e., top of the paper north, right hand side east, etc.

In making notes in a field book or plotting the results on paper afterwards, an indelible pencil should never be used. The first drop of water makes a terrible mess of everything, and ruins any work done with such a pencil.

Compass "Bearings".

The "bearing" of one point from any other point on the map may be read directly from the map by the use of a protractor. The angle between the two points on the map, that is, between the true north and the point observed, being always expressed in degrees. These degrees always start at the true north and read from left to right, or with the hands of a watch or the way the sun turns. **Bearings Are Never Measured From Right to Left**

or Counter Clock Wise.

In Plate No. 14 an example of the "bearing" of one point from another is shown. A is the point the observer is standing on and N is the point or object he sees in the distance. The "bearing" of the point N from A is 43 degrees, because it measures 43 degrees reading from the true north point, shown by the arrow head, to the line A-N. If the point N was anywhere along the line A-N, its "bearing" would still be 43 degrees, as the angle from the true north line to the line A-N always has the same reference to each other, **no matter how far apart the two points A and N may be.** In this example no reference to magnetic north is made, and the bearing is a true "bearing".

The difference between a true north and a magnetic "bearing" can be seen at once by referring to Plate No. 4 on the right of which is shown on a large scale, true and magnetic needles placed on the map with proper reference to their key direction pointers, which are printed on the right-hand margin of the map, as indicated by a black arrow.

It will be noticed that the black line with the **STAR** top at **Y** stands perfectly perpendicular with the up and down line of the map "grid". This is the true north pointer, and they are always indicated by having a star top; consequently, as all the up and down lines of the "grid" correspond in direction with this true north pointer, in taking a bearing anywhere off the map you can use any of the up and down lines of the "grid" as a guide to the True North.

The other upright line at **Y**, with the arrow point head, is the magnetic north pointer, and your compass which points to magnetic north would correspond with this pointer when your map is "set" or "oriented". This pointer leans off to the left at an angle of 15 degrees 30 minutes, which means that at this point on the earth there is a compass variation of 15 degrees 30 minutes west, because the magnetic pointer is on the west side of the true north pointer. If the variation had been **EAST** the magnetic pointer would have shown on the right hand, or east side of the true north pointer.

In Plate No. 15 are shown the lines of magnetic variation over the whole surface of the earth. By a careful study of this plate a lot of useful and important information can be acquired, and many points which at first appear difficult, such as the question of compass variation, can be clearly traced out. Instructors should take time and care with the subject of variation, and see that every man understands the question from a practical point of view.

In all reports and messages, "bearings" are always given true north; in other words, if a certain object was observed as having a magnetic bearing of 233 degrees and the local variation was 16 degrees east, this magnetic bearing of 233 degrees would be corrected by **ADDING** the variation to the "bearing", 233 degrees + 16 degrees = 249 degrees, and the correct true north bearing of 249 degrees would be given in the report or message as being the "bearing" of that certain object from where the observer was standing.

As an example of converting a magnetic to a true bearing, see Plate No. 14. The observer is at the point T and in the distance he sees an object at V. He takes his compass and after sighting on this object he finds that it has a magnetic "bearing" of 266 degrees 30 minutes from the point T to V. Now there is a variation of 15 degrees 30 minutes west at this point on the map, consequently he would deduct 15 degrees 30 minutes from the 266 degrees 30 minutes, leaving 251 degrees, which is the "bearing" from the true north pointer, measuring around in the way the hands of a watch turn, **and this is the true "bearing" he must send in** when making out his report of message.

In taking "bearings" with an ordinary dry card compass, it is a good plan to take two or three sights of the desired object, if time will permit, and take the mean of the three sights as being the correct "bearing". **Always remove your steel hat** and any other iron or steel equipment, such as a slung rifle, etc. They set up a local attraction which makes the compass read too much or too little, and in some cases make it act "wild", reverse and be entirely useless—consequently, on reaching the position you want to take your compass sights from, don't forget about removing any equipment that will interfere with the proper working of the compass.

Converting "Bearings".

When the variation is west.

A magnetic bearing is converted into a true bearing by subtracting the variation.

A true bearing is converted into a magnetic bearing by adding the variation.

When the variation is east.

A magnetic bearing is converted into a true bearing by adding the variation.

A true bearing is converted into a magnetic bearing by subtracting the variation.

As all compasses have what is commonly called

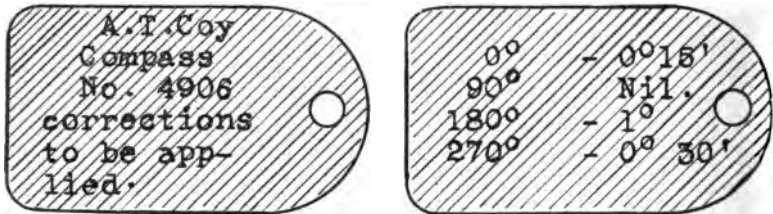

Example of Tag, Showing Compass Errors

a "personal error", this will also have to be taken into consideration when correcting a compass bearing. All good instruments have a small tag attached to them, showing the "error" of the compass at the four quarters, that is, at 0 degrees, 90 degrees, 180 degrees and 270 degrees. This tag gives you the error to be subtracted or added when taking a compass reading in that particular quarter of the compass card. All good manufacturers prepare and attach this tag. This is called the "calibrating" of the compass.

When there is no tag giving the personal error of the compass, it is always advisable to find out at once how much your compass is at fault, and furthermore, every compass must be tried out from

SCALE 1-10,000

ALDERSHOT DISTRICT. (south.)

SHEET NO -

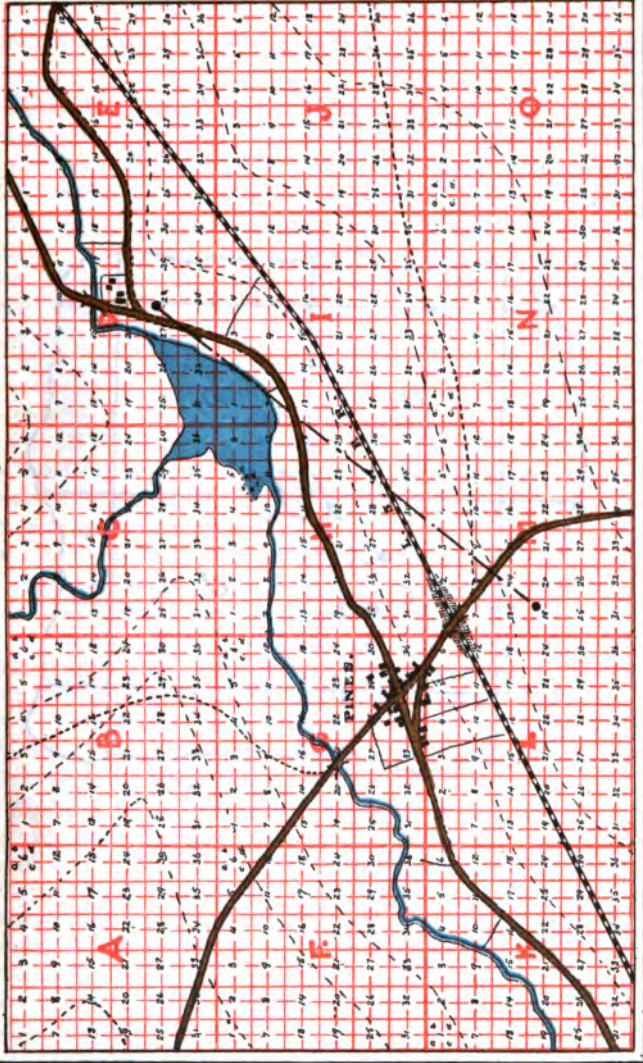

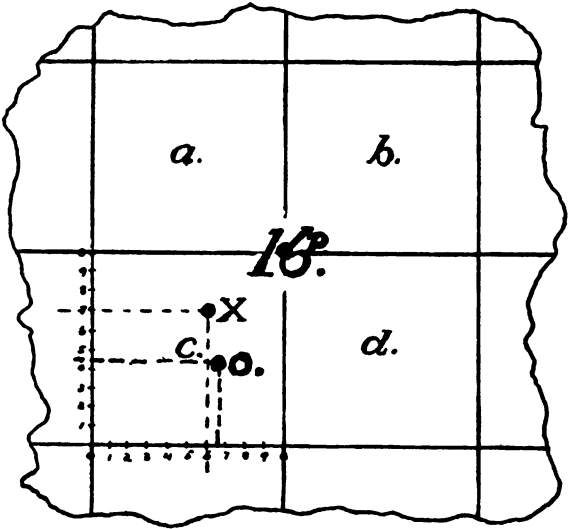

100 1000
10000 100000

time to time to see if their personal error remains constant.

Two easy methods of making this test on a compass are, first, by the north star at night. Take an observation, and the observed difference between the bearing of the north star and the "luminous" north point on the compass card should correspond exactly with the local variation. **As an example, the observed difference between the north star and the compass "luminous" north point is 17 degrees.** We know by looking at the map that there is a variation at this point in the country of 16 degrees; consequently there is a difference of 1 degree between what we should have and what we really did get, and this means that our compass is **reading with 1 degree too much westerly variation,** and the thing to do with this instrument is to **always allow for 1 degree extra west variation** and the error of the compass will be about right.

Another method is shown in plate No. 3, at the left hand upper corner. To look at this sketch in the proper manner you should be facing west on the map. **This demonstration of getting a north line for correcting compasses, etc., can be done any day in the year when the sun is shining—but must be done when the sun is at its zenith distance, or half-way between sunrise and sunset.**

Make a tripod of three sticks as shown, the back leg to extend over the two support legs, the point A of the back leg to point in a northerly direction when setting the tripod up; smooth off the ground below and in front of the point A, and from the point A of tripod drop down a plumb line and establish on the ground the center point T. From this point T, by means of a piece of string, draw a circle about one and one-half foot radius. It is only necessary to draw this circle on the north side of the point T (circle shown in cut by heavy

black line). Put a small wooden peg in the point T so as to keep it well established.

Watch the equipment for fifteen minutes before and for fifteen minutes after the sun reaches the zenith and you will find that the shadow of the end of the tripod at A will travel in a circle from about H around from left to right following the course of the dotted circle with arrow heads indicating direction the shadow moves in, until it forms another perfect circle and has crossed the circle marked on the ground, at the two points marked X and X. Mark these two points exact, and at a point half way between them, and from the point T draw a straight line, E. This line will point true north, and by opening the compass and laying it with this line as a center line, you can see at once the error in the compass variation.

The upper part of the sketch showing a heavy circle with three balls marked, before 15 minutes—noon sun time—after 15 minutes, represent the sun in the three different positions. And the circle the direction and course taken by the sun from east to west. The sketch has been "oriented" on the map to give a general idea of how the equipment should set and operate with reference to the actual demonstration in the field.

Back Bearings.

When the bearing between two points is known, say from A to N, plate No. 14 (43 degrees), the bearing from N to A can be arrived at approximately by taking the bearing 43 degrees and adding half the diameter of the compass card or 180 degrees. This gives a "back" or "return" bearing of 223 degrees. Bearing procured in this manner can be used for returning from night marches or patrols with very satisfactory results. The corrections for personal error of compass

when moving in different or opposite directions must be taken into consideration.

Rule for Getting "Back Bearing".

If bearing is less than 180 degrees, add 180 degrees.

If bearing is more than 180 degrees, subtract 180 degrees.

Re-sectioning or Triangulation.

The system of locating a point on the map by re-sectioning or triangulation is shown on plate No. 3. The observer, who has no map with him, is standing at the point A, and in the distance on top of a hill, he sees some object he wishes later to locate on his map. He takes a compass "bearing" on the object, getting a true bearing after allowing for the local variation of 20 degrees. This bearing in itself would be of very little use, as the object might be anywhere along the line A-T; so after taking the bearing 20 degrees, he turns to the right and takes another "bearing" on any convenient object 300 or 400 yards away. This object is at a bearing of 102 degrees 30 minutes. After making notes of what he has done so far, he proceeds to pace along this last line of bearing until he has gone 400 yards and arrives at the point V. He then takes another bearing on the point T and gets 327 degrees 30 minutes after again making corrections for the variation.

When he returns to camp he takes his map and locates point A, then draws a pencil line from this point with a bearing of 102 degrees 30 minutes, forming line A-V, measures off 400 yards on this line and establishes a "base" line with the two points he was standing on marked on it, points A and V. **Then from point A** he draws another line with a bearing of 20 degrees and **from the point V** draws a line with a bearing of 327 degrees

30 minutes, and where these two lines intersected and crossed each other the point T is located.

Method of Squaring Off Service Maps

Service maps on the scales of 1:10,000, 1:20,000, 1:40,000 are now divided in such a manner as to allow of ready reference. On the surface of the map is printed a series of **vertical and horizontal lines, generally printed in red ink**, which break the area up into squares whose sides represent a distance on the ground of 1,000 yards. These squares are aggregated into groups, each group under a block capital letter. Fig. 1 represents a map with 15 groups, the groups being lettered from left to right, commencing at the upper left hand corner of the sheet, i. e., A, B, C, D, E, and clearly continuing F, G, H, I, J on the lower series of groups.

Each group in turn is divided into either 30 or 36 1,000-yard squares, which are each given a number. Starting with the upper left hand corner again and reading across the top six squares, thus, 1, 2, 3, 4, 5, 6, and then back to the left hand side and on the next lower line of small squares 7, 8, 9, 10, 11 and 12, and so on down until the group of 30 or 36 squares have each been given a separate number.

Each numbered square is again subdivided into **four quarters** of 500-yard sides, referred to (as shown in Fig. 2) as a, b, c, d.

To report a position, the group, square number and quarter square letter are first given in order to define the square referred to; thus the point marked X is in A 16 c. The exact definition of the point within any given square may now be indicated by its **co-ordinates**; i. e., its distance to the right from the left hand lower corner of the quarter square, and its distance upwards from the

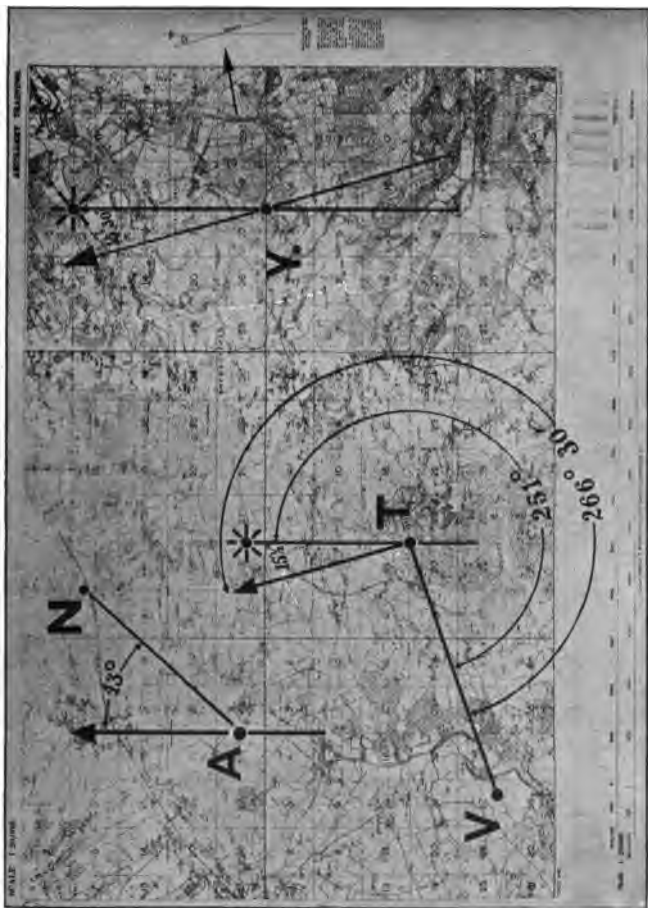

SQUARED SERVICE MAP

same starting point (each side of every quarter square side being again divided into ten equal parts). Fig. 2 (Refer to cut No. 13) shows square A 16 magnified as it would appear on a much larger scale than Fig. 1. The point X lies in A 16 c. Its measurement from left to right in the quarter square c is 0.60-tenths, and its distance upwards from the lower line of the quarter square is 0.70-tenths. This particular spot on the map would therefore be reported as A 16 c 60-70.

The number 10 is never used. The point P. Fig. 2 may clearly be said to be connected with A 16 a or in A 16 c, or in A 16 d, or in A 16 b; but to allot it to either of the first three quarter squares would involve the number 10 to describe the measurement from left to right, or from the lower line upwards. The only square not having this disadvantage is A 16 b, and when allotted to this square its measurement from left to right is zero or 0.00-tenths, and its measurement from below upwards is again zero or 0.00-tenths. Consequently its map location would be reported as being A 16 b 00-00.

In defining the co-ordinates it is best to use two sets of figures, with always two figures in each set; that is, 60-70 in a case where the point that you wish to report comes on exact intersections of the two lines as shown in Fig. 2. In a case where the point would come, say, half way between 60 and 70 on the lower line, and half way between 40 and 50 from below upwards use two figures again, only in this case the reading would be 65-45 as at 0 in Fig. 2.

In reporting map locations by this method, the left to right co-ordinate must always be given first, and the upward co-ordinate second.

Bearings on the Squared Maps.

Note that the vertical squaring or "grid" on a service map does not always come true north and south. In a case of this kind where the "grid" is off from the true north, you will find printed on the left hand side of the map and crossing the most left hand vertical line of the "grid", an arrow pointer or needle, which will show in degrees how much error there is, east or west, between the upright lines of the "grid" and true north point, and in taking bearings on the map by means of the "grid" lines this error of the "grid" must be taken into consideration as well as the local variation.

Thus: You want the **magnetic bearing** between two points. In Fig. 1 (Refer to cut No. 13) the "grid" bearing from the point M 19 b 50-50 to D 28 a 50-50 would be 38 degrees, and if the "grid" was correct true north and south, all you would have to do to convert the "grid" bearing to a magnetic bearing would be to add the local variation, which in this case is 15 degrees 30 minutes.

But suppose your "grid" was off, say 3 degrees 10 minutes east from true north; you would get 3 degrees 10 minutes less angle in taking your bearing and instead of adding only the local variation of 15 degrees 30 minutes you would also have to add the 3 degrees 10 minutes error of your "grid", or a total of 18 degrees 40 minutes to bring your bearing from the bearing as got from the "grid" to a magnetic bearing.

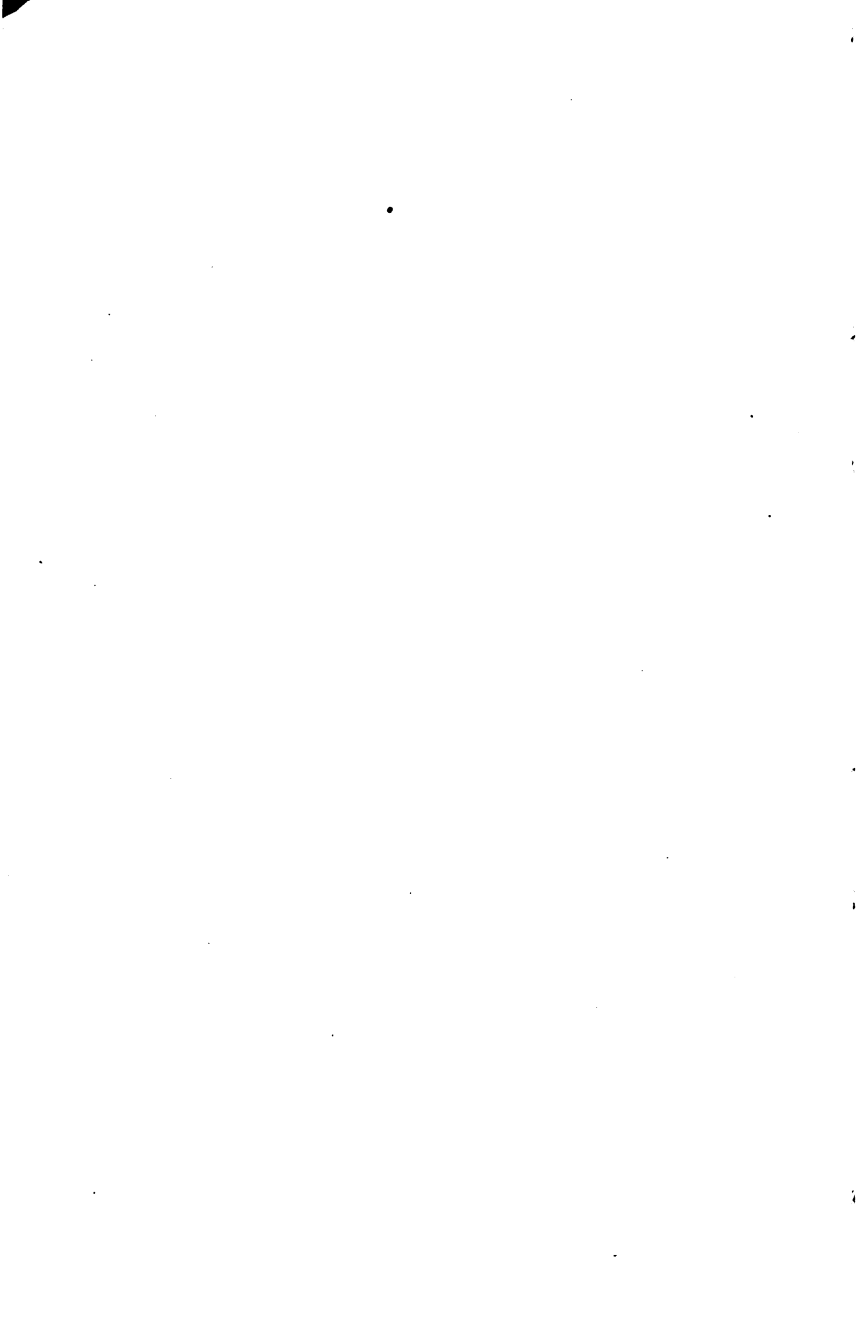

CHAPTER III.

Instruments and Equipment

Mark VII. Service Prismatic Compass. (English.)

This type of compass has been designed for the use of general military map work and use in the field in taking bearings, and when properly taken care of, is capable of doing very accurate work in the hands of the ordinary man.

Care must be taken not to give the compass any hard falls or jars, as the center pivot which supports the compass card and needle is subject to being easily damaged, and it will put the instrument out of commission at once should this pivot point be broken or bent. It is also advisable to keep the instrument, when not in use, away from rifle racks or other places where there would be a strong local attraction. This local attraction weakens the compass action, making work in the field very much slower by the weak movements of the needle.

Always see that the clamping screw (H) is pulled into place when through with the instrument; this prevents the compass card from having any movement, as well as raising the card and needle from the pivot, and prevents damage to any of these parts when being carried in the case.

This service compass consists of a magnetic needle (A) balanced in the center of a pivot. In the center of the needle is a small brass boss which holds the needle, the compass card or dial (B) and the pivot jewel (T) together. This jewel bears on the point of the pivot, supporting the weight of the needle, dial and brass boss, and gives a clean, easy bearing for the compass dial to revolve on.

The dial (B) is marked off by two methods. On the circumference or rim it is divided into 360 equal divisions; these are termed degrees. This scale is for use with the prism (G) and is numbered off exactly opposite to the inner or correct set of compass points. **By examining the Plate No. 17**, you will notice that the arrow, or line of sight, is directly north and reads north on the inner set of compass points. Now if you were to try and read this bearing by looking down through the prism, you would get exactly the opposite, or 180 degrees; so in order to get the correct reading in both cases the outer set of figures are moved around on the card or dial just half a turn, which would give you the correct compass reading by using either of the graduations.

The metal box or casing (C) is for the purpose of holding together the different parts of the compass, and at the same time protecting them. It is brass and enameled black or some other dark color. All good compasses have a leather case which the compass box (C) fits snugly, this outer case being provided with a strap for carrying over the shoulders.

The metal cover (D) opens on the hinge (d). This cover has several duties; when closed down it protects the glass face of the compass box (C); **when opened to an angle of 45 degrees**, as shown in plate 16, the cover holds in position the **black hair line F-F** by means of which and the prism slot bearings are taken of the desired object. When the cover is **opened to an angle of 180 degrees**, so that the top of cover and bottom of compass box would both lay flat on a table, the notch (R) at the top lug on the cover, and the notch (R) on the brass ring (K), would give the exact center line of the instrument, which is required when "setting" maps, etc.

The metal cover also holds in place a glazed window (E); this glazed window has a fine black hair

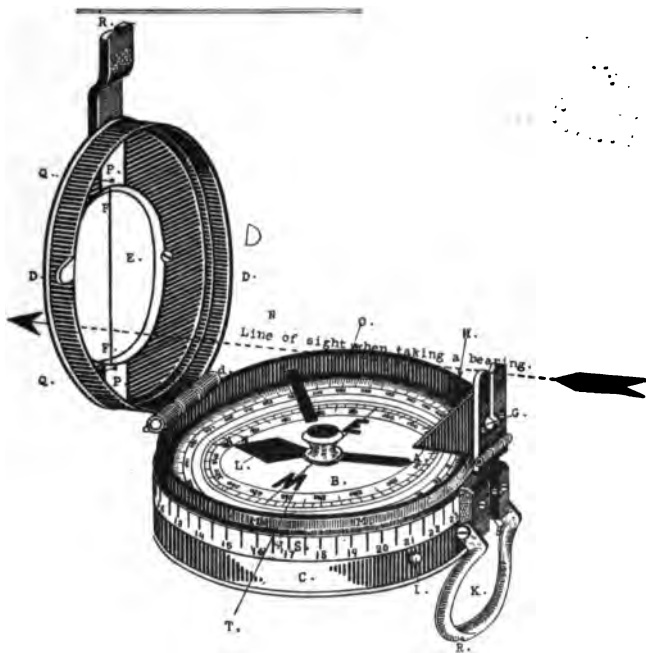

MARK. VII SERVICE PRISMATIC COMPASS (English.)
(Enlarged Sketch.)

- | | |
|---------------------------------------|---|
| A. Magnetic Needle. | L. "Luminous" North Point. |
| B. Dial. | M. Revolving glass cover. |
| C. Metal box or casing. | N. "Luminous" direction mark. |
| D. Metal cover. | O Brass clamping screw (not shown.) |
| d. Hinge. | P-P. "Luminous" patches for night work. |
| E. Glazed window. | Q. Small holes for holding hair. |
| F-F. Fine black hair line. | R-R. Notches for placing compass on a N. and S. meridian for "setting" map. |
| G. Prism. | S. Graduated dial for setting Direction Mark when on night work. |
| g. Slot to permit focussing of prism. | T. Pivot jewel. |
| H. Clamping screw (not shown). | |
| I. Check spring to steady dial. | |
| K. Brass ring for holding compass. | |





Liquid Prismatic Compass (English)

For General Description see Plate No. 17



line F-F traced on its inner face. Should this glazed window become broken, provision is made for making a temporary repair in the two small holes, Q-Q. A fine thread or horse hair can be tied across the opening left by the broken window and answer for taking bearings until proper repairs can be made. The cover also holds in proper place the two luminous patches, P-P, which are used for night marching.

The prism (G) is a small metal casing containing a mirror set in at an angle of 45 degrees by means of which the graduations on the outer rim of the compass card can be read. There is also a slot running upright in the prism; by looking through this slot and bringing the hair on the cover (D) in line with the object in the distance, you can at once read the compass or magnetic bearing of the object from your position. The prism has a leg projecting down which runs in the slot (g). This permits the prism being raised or lowered for getting a proper focus on the compass dial.

The clamping screw (H), not shown in plate, is a sliding arm with a screw projecting through the casing, and is for the purpose of locking the compass needle and dial up off the pivot, preventing damage to any of these parts when compass is not in use.

The check spring (I) is to steady the compass card or dial swing when bearings are being taken.

The brass ring (K) serves the purpose of holding the compass up while in use taking bearings.

The "luminous" north point (L) is painted on the compass dial with a special preparation, which when exposed to daylight for about half an hour will give from six to nine hours' service at night as a "luminous" point. This broad arrow point is the north point on the compass dial.

The revolving glass cover (M) covers and protects the inside of the metal box (C) from dirt and damage. It also carries on its face the "lumi-

nous" patch (N) called the "direction mark" on the outer edge of the revolving glass cover there is a small notch or zero point. This notch is used for the purpose of setting the "luminous" point in the correct position for night work.

The scale or graduated dial (S) marked around the outer edge is the graduation the zero mark on the glass cover (M) is set by.

The brass clamping screw (O), which is not shown, is a small thumb screw with a knife edge for clamping the revolving glass cover stationary after the desired course has been set.

This compass the service mark VII is of the type termed a "dry card compass", and there is no liquid filler in the compass box or casing. This does not affect the proper working of the compass in the slightest, but in taking bearings with this type of military compass it takes considerably more time than with one of the liquid types, as the card or dial moves so much freer, consequently takes much longer to steady down on a bearing, thereby enabling the observer to read his course.

The wet or oil-filled compass costs considerably more than the "dry card" type, but every intelligence section should have at least one good oil-filled compass for night marching and the taking of quick bearings. This instrument will generally be carried by the officer or sergeant of the section, the greatest care should be taken of it. Every man in the section should be given plenty of chance to use and become familiar with this special compass, and they should each have personally a compass of as good a type as the service mark VII.

The Trench Sniperscope.

While the trench sniperscope is a rather heavy and awkward instrument at the best, a great deal of good work can be done with it when in the hands of an expert man. At 100 yards any good

shot can make a 4-inch group, and when you take into consideration the fact that the operator is safe from rifle fire, from the enemy snipers, and at the same time has a very good command over his trench by means of the sniperscope, it has become a very useful addition to the sniper's equipment.

There are several different types of sniperscopes in use, the one shown in plate No. 19 being the most common of the cheaper and quickly set up and adjusted types. They are easily damaged and put out of order, and when not in use should be put away where the snipers personally can be responsible for their safe keeping. The periscopes that are attached to and belong to the sniperscopes should never be taken off and used for other purposes. When the sniperscope is required there is no time to run around through the trenches looking for the periscope to fire it with.

A general description of the types shown in plate No. 19 is as follows: The rod A is made of $\frac{3}{4}$ -inch bicycle tubing, flattened at the upper end to receive a $\frac{3}{8}$ -inch hole through which passes the small bolt with thumb screw; this secures the flat band around the wood of the rifle stock and the upper end of the arm A together. At the lower end of the arm A is a hard rubber hand grip. The left hand of the operator takes the instrument at this point when in use. This rubber hand grip has an inner metal tube which is threaded with a right thread one end and left thread the other, the tube A screwing in the upper thread and the small stud from the butt F fitting into the lower end. By turning the hand grip J with the left hand the operator can adjust the alignment of the sights and periscope E.

The butt F is made of wood and is fitted on the right side with a sliding bolt action somewhat similar to the action of the rifle. This action is

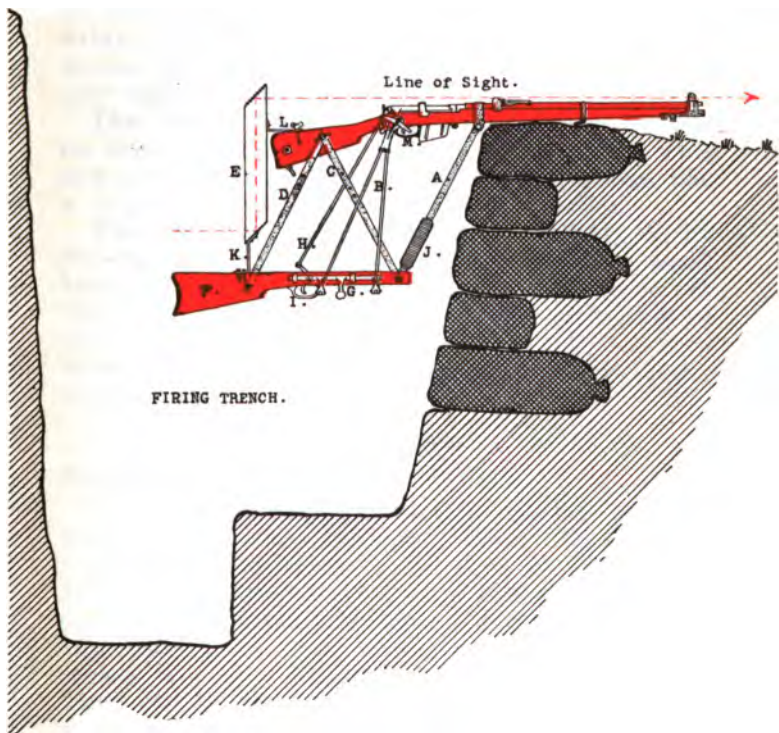

[Faint, illegible text on the left page, possibly bleed-through from the reverse side.]

[Faint, illegible text on the gutter of the book.]

READING
right
the h
marke

onst
oint
ds
w
n



attached to the rifle bolt by the two arms, B. When the bolt, G, is first raised, then drawn back, the rifle bolt is given the same action, thus extracting the empty shell; then on the bolt being driven forward and turned down, the rifle bolt goes through the same action, and slips a new shell in rifle barrel and locks rifle bolt in position for firing. The butt, F, is attached to the rifle by means of the flat arms, D and C, and is adjusted and supported by the arm A.

The rifle is fired by means of an extra trigger on the butt, F, which operates an arm, H. This arm works a small cross bar with the end bent like a finger, and is attached to the bolt action.

The periscope, E, is attached to the butt, F, by the standard, K, and to the rifle butt by small brace, L, which is secured to butt by thumb screw. This type of sniperscope can stand a great deal of improvement, which no doubt they will be given when the usefulness of this instrument is better understood.

Instruments.

Telescopic Rifles.

1. **Every intelligence section** should have at least six first class telescopic rifles. There are a number of good sights of this class on the market, and providing they have a good field of vision, and are easily adjusted and zeroed, and not too bulky and heavy, they all do good work up to 400 yards, which is about the limit that will be required. They can be fitted to all the regular military rifle arms.

Heavy Caliber Rifle.

In addition to these arms each **section should have one heavy caliber rifle** for firing on enemy snipers' posts. This rifle will very often drive out a sniper by piercing the plate in

front of him, when the ordinary .303 will do him no damage. Specially hardened steel bullets are necessary for this arm. This rifle comes in good on indirect fixed rifle fire, the curved trajectory above 400 yards making it useful in reaching slopes and points that the service arm will not handle.

Periscopes.

2. **Each section requires four good magnifying periscopes**; they should be as light and compact as possible, and from plus 8 to 10 in power. Plus 6 is a little weak, and over 10 is too sensitive for the ordinary man, and he has poor results from their use. A short periscope is dangerous as the enemy is liable to spot a man using the glass, and get him by firing through the trench parapet. Trench parapets should be strengthened at the points the periscopes are to be used.

The ordinary mirror periscope is of little use unless a good single glass is used in connection with it. Any pair of good 8 or 10 power field glasses can be used for this purpose, and where a proper magnifying periscope is not available very good service can be secured in this manner.

Periscopes should be disguised by a sand-bag or other means and exposed over the trench top slowly and with care, and held steady, when in use, and should have a safe place in the trench wall for storing them when not in use.

Range Finder.

3. **Several good magnifying range finders** are now available. The intelligence section should be in possession of at least one, and every man should have lessons in its use and adjustment. The proper use of a range finder is simple and of the greatest value; men should be made to understand their value and to handle the instruments with care,

placing them away in their case with the adjusting heads closed, etc., as soon as the work is finished.

Field Glasses.

4. Each man should have a good 8 power pair of field glasses issued to him, and be made personally responsible that the glass is taken the proper care of, and used in the proper manner. The ordinary glass issued is rather bulky, and an effort should be made to secure a smaller size.

The men should carry these glasses every day during the training period, and use them on all occasions that a glass would be of use. By this means they soon become accustomed to their use, and realize their value.

An 8 power glass will, in use as a night glass, increase the power of vision about 50 per cent. Tests on night work at different color of uniform, troops, camps, country, etc., should be carried out, as it is only by this means men can judge with any amount of accuracy just what their glasses are worth.

Machine Gun Levels.

5. These levels are useful in working up indirect fire positions, and a rifle can be set very exactly by one of these instruments. It is also necessary to have a first class compass to direct the fire of the gun or rifle.

Maps.

6. The service military map is as a rule printed on light paper, and in most cases, especially in the field-printed one, unmounted, or backed by cloth. When these maps come unmounted, the first thing to do with them is to proceed at once to lay them out flat on their face and paste on the back cheese cloth, or some other light cotton material. This protects them when folded and in

use. A simple way to prepare the paste and apply it to the cheese cloth is to take flour and water, stirring the flour in the warm water until the paste gets about as thick as syrup; then take the square of cheese cloth and put it right into the paste, stirring it around until thoroughly soaked. Then wring it out and lay on back of paper map, smoothing it well out, and finishing the drying with a warm flat iron.

Every intelligence section should take a pride in the condition in which they keep their maps, and when a map is of no further use, destroy it. Old maps lying around are neither useful nor ornamental. The trench maps made by the section are generally copied off on a foolscap size of paper and do not require backing, as they are only used about once or twice, and then destroyed.

The Fixed Rifle Stand.

The fixed rifle stand has not as yet become standardized as a great many of the best informed officers on the subject would like to see it. Up to the present time, whenever a fixed rifle would be useful in the trenches, owing to some special situation whereby the enemy could be harrassed in their night work, and considerable losses be inflicted upon their rank and file, some handy man in the party always has to construct some kind of an amateur fixed rifle frame, of any materials that are available, and in most cases very good firing has been done by even these crude means.

The French have several types of fixed rifle stands now in use, largely constructed of wood. While wood, if properly treated and thoroughly covered with good paint, will stand considerable outside work, it is only a question of a short time until a stand built up in this way becomes warped and twisted so they are of very little

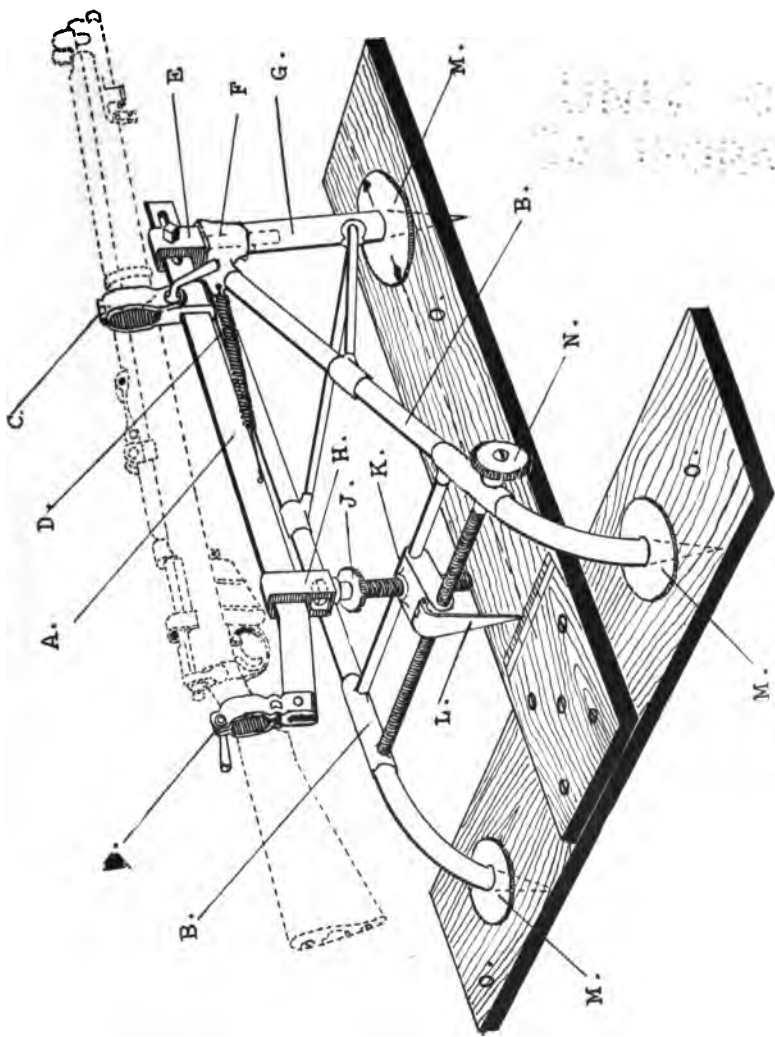

10 100
100 1000

use in close working of firing problems. One good point, however, about the wooden stand is that it can be "set" with the compass, and little risk of your "bearing" being out through local attraction. In England several types of metal stands are being worked out; some are very good ideas; others will never be of any practical service owing to weight, size and no adjustments.

A combination of wood and metal will possibly be the most satisfactory. In the stand shown in plate No. 20 a light and strong frame is built up of steel bicycle tubing, and on this frame is mounted the stiff leg with clamps to hold the rifle in place. Underneath the metal frame, a rough wooden T square of plank, with three holes bored in the proper place to take the spike legs of the metal stand. The T square of plank is first "set" with center line on the plank on the "bearing" required, and afterwards the metal stand and rifle are brought along, placed in place, and by means of the hand adjustments on the metal stand, any slight alterations required in the "lay" and "bearing" of the rifle can be taken up.

Indirect firing with one of these rifle stands is one of the most interesting and exact pieces of work that the intelligence section is called upon to do, and the time spent in instructing and working out problems with this equipment is time well spent. You will find that every man takes the greatest interest, and wants to know how every move is made. The result is that they learn how to handle and direct not only the fixed rifle stand and its arm, but they learn more about their own rifle than they ever thought was in the weapon, and in the end with practice become more proficient in the subject of indirect firing than the average machine gun operator.

Instructors must remember that this is entirely new work for the average man, and that they will

have to exert great patience with their class and teach them from the ground up. Most men want to know and learn this class of the military training, and by taking the time and in odd cases giving some individuals a little extra explanations, you will get men to use their rifles and direct their fire when and where you want it.

As before stated there is no standard type of fixed rifle stand, but a short description of the one shown in plate No. 20 may possibly help to have this type improved on and brought into general use. The steel arm, A, runs through two guides, E H. These guides are fitted closely to the arm, and allow it to move backward on the discharge of the rifle without letting the arm lose its direction or elevation. At the forward end of the arm, A, will be noticed a slot. This slot extends for some 2 inches and a pin or set screw passes through the forward guide, E, for the purpose of keeping the arm, A, into the frame and at the same time allowing it to slide back and forth. On the arm, A, are mounted two rigid clamps, C C, which are for the purpose of securing the rifle in place. These clamps are made to fit the wood of the rifle stock close, and should be turned up good and snug, with a piece of felt between the stock and the clamps. Otherwise they will set into the stock and mark it.

The adjusting screw and hand wheel, J, is attached to the guide, H, and works in a tread in the block, K. This adjustment is for elevation of the rifle and should have a range of at least 15 degrees.

The adjusting screw and hand wheel, N, works in two bearings in the tube frame, and gives the rifle the adjustment for the compass "bearing", by shifting the block, K, from left to right or right to left as desired, and causing the arm, A, to swing on the pivot at F on the block K is hung a pointer,

L. This will give the degrees right or left of the center line, by adjusting with the hand wheel, N, and reading the quadrant scale marked on the plank frame.

The metal frame, B B, is constructed of steel bicycle tubing with reinforced joints and all brazed securely together. On the ends of the legs at M M M are brazed flat feet which answer the purpose of preventing the frame from working down into the plank or ground, should it be "set" either way. The ends of the tubing below the flat feet, M M M, are brought to a sharp point and give the frame a toe hold in the ground. **The plank frame, O O O,** explains itself and does not require much of a mechanic to construct.

In using a stand of this description, as it weighs only some 15 pounds without the rifle, after the wooden frame has been "set" on the desired bearing and the metal stand has been placed on it, a couple of sand bags should be used to place against the front leg, C. This will keep everything solid and prevent shifting when the rifle is fired. Care should be taken not to lean the sand bags against the return spring, L.



CHAPTER IV

Information—Reconnaissance— Observation

Reports on Topography.

Many men get the two words topography and reconnaissance into their minds under the misunderstanding that the two words mean practically the same thing, which is entirely wrong.

Topography mean a written or spoken description of the minute details of a country, district or place.

Reconnaissance, on the other hand, means the act of securing this information, either by actually going over the ground, or by observation from some commanding position.

In other words, after walking over a certain piece of country, you would be able to make "a reconnaissance report on the topographical features" of that particular piece of country.

These reports should be clear and concise, and bear on the subject in hand; should give all possible information that will be useful for the operation in view, for which the reconnaissance was made.

Reports are generally classified, each subject being under a separate marginal heading, in order that the officer who receives the report can at a glance find the particular information he desires.

Various Readings With Details to Report On.

Road.

1. The roadway, classification, metaled or not, width of metaled portion, what kind of metaling, present condition, will it hold under traffic, whether

level, hilly, straight, any sharp turns to delay traffic, the steepest gradients to be stated in degrees. Details of any kind which would constitute a defile, such as a narrow bridge, arches over roadway, their height and width, village streets, embankments or ditches, the nature of the fences, hedges and trees along the roadway.

Bridges.

2. **Full details**, material of construction, width, length, height, how many piers, what are they made of, how high is bridge above water, is there any material at hand to repair it, what kind of material it is, if the bridge is destroyed are there any boats, barges or pontoons available, timber and planking for decks, can the boats or barges tie to the up-stream side of the bridge or are they down-stream, can they be gotten to the road, if not, can a road be made to them without delay, are there any fords?

Rivers.

3. **Their depth**, width, rapidity of the current, nature of the bottom, banks and approaches, also if any fords, where are the bridges, what kind they are, would it be a difficult matter to rebuild them, or could the engineers get their pontoon bridges in, and could you get guns and transport to them? What cover is there along the banks, could the infantry command the opposite side, etc.?

Railways.

4. **Gauge**, single or double track, what rolling stock is available, is it in good order, what is the condition of the loading platforms and buildings, is there much coal, supplies, material or tools, any wrecking cars, are any of the working crews available, what condition is the road bed in, the bridges and tunnels, where does the line run to and where is it from, has the road a telegraph system, is

it in order, have you examined any of the road bed for mines or other obstructions? In reporting on anything special always give the map location, the commanding officer can then take steps to protect himself and his troops.

Water.

5. **Send in the map location** of water to be found along the road or line of march, is it good and fit for drinking, are the approaches to it good, how many horses can be watered at one time? Full information is required on this subject.

Villages.

6. **Material of the houses**, inflammable or not, buildings suitable for barracks, store houses, magazines, hospitals, how many men roughly will they billet, are the inhabitants still there, who are they, what stores of man and horse feed are still available, are there any suitable entrenching tools, horses, wagons or other equipment? Can the village be defended, and what is its map location and name?

Marching.

7. **Anything** that is going to retard or otherwise alter the rate of marching, such as narrow bridges, arches over roadways, gates over railways, etc. Definite information under this heading is of the greatest importance.

Halting Places and Camps.

8. **Halting and shunting places** where parts of the column could be brought forward, camping and bivouac ground, what size force will it handle, is the water and fuel close, could it be protected by the force available?

The Country.

9. **Class of cultivation**, what condition are the fields in, soft or hard ground, could infantry, guns

or transport travel on them, are there many marshes or small streams which would delay the column, what kind of timber—heavy or light—or any? View: is it restricted or open, is it far across country to the parallel roads, are there any cross roads, are they clear, are there telephone lines, telegraph or other means of communication along the main road and to the parallel roads, are these lines in good condition?

Scouts and Patrolling

In the field service regulation it is laid down that a force is not protected from surprise unless it has under observation the enemy as soon as they move. One of the ways in which to prevent a force from being surprised is by scouts. It does not matter whether it is in the trenches or in open warfare, scouts are of enormous value for that purpose.

Whether in open or trench warfare the last part of the scout's movement is bound to be much the same as a patrol, and the scouts are able to get good information which will be of value to the higher commanders.

Open Fighting.

In open scouting, the scout must remember that his object is not merely to report that the enemy are at such and such a place, or that he was fired at from a certain point. There are always details on which to report.

- (a) The best route to bring up troops.
- (b) How far the infantry can come in artillery formation.
- (c) The best point from which to observe the enemy's movement.
- (d) Good positions for guns, machine and Lewis guns.

- (e) The flanks of the enemy (if any).
- (f) To distinguish between the enemy's posts and his main line.
- (g) Whether there are any trenches held by the enemy and if so how many lines.
- (h) Whether there are wire entanglements—this should be especially looked for in sunken roads, woods, streets, etc.
- (i) The best road for retirement if necessary.
- (j) The best line on which to attack if occasion arises.
- (k) Water supply for men and animals.
- (l) Cellars for use as headquarters, etc.
- (m) Bridges, and fordable points in a river, etc., etc.

How to Carry Out These Suggestions.

In order to obtain the best information and transmit it to the attacking troops, it is essential for the scouts to work at least 400 to 500 yards in front of the main line of attack. By so doing they run greater risks, but a single man moving quickly and with care presents a smaller target.

The shortest route is not always the safest or quickest. It is useless to obtain information which cannot be passed back to the main line of attack; therefore, no unnecessary risks should be taken and every means of cover such as hedges, ditches, etc., should be used when possible.

Roads and tracks must be avoided.

Woods should be carefully searched for the enemy:

Experience has proved that scouts should work in groups of three or four. Groups of four stand a better chance of getting in touch with the enemy so as to transmit information and to keep the enemy's movement under observation. If this plan is adopted two of the party should work in front, the third some way behind, and the fourth behind him again,

but near enough to be within sight and hearing of the man next in front of him.

When information has been gained by the scouts it is important for them to transmit it back as rapidly as possible. It must be remembered that scouts present a target to the enemy when returning with information probably greater than when going out to get it.

Trench Warfare—Patrols.

The training of scouts for patrol work is in many ways difficult. But it is essential for men to receive instructions before patrolling in face of the enemy. There are many points which can only be learned when on patrols between the lines. Good common sense and a cool head are the greatest assets to a scout.

At the beginning of the war inefficient patrols were sent out which caused unnecessary casualties. We then started a system of training and we insisted that no officer, non-commissioned officer or man should be allowed to go over the top until he had had at least five days' actual training in the proper conduct when patrolling.

To train them in what are the first essential things.

It must be remembered that in trench warfare nearly all the patrol work is carried out by night. It is therefore essential for scouts to accustom themselves to work in the dark. Many men will become almost paralyzed with fear if a hostile patrol should suddenly appear. Continual practice in movement in the dark lessens the fear which men have in the night, and it is only after much experience that men are enabled to distinguish between bushes, logs, etc., and an enemy patrol.

The next thing is to teach them to be able to find their way in the dark. This is probably harder,

but it can be done. Some men, especially men from western Canada and the United States who have had years in the bush trapping and hunting, can keep their directions and find their way back in the dark; however, you will find it much easier if you remember one or two things.

1. **Always notice land-marks** that are going to be guides and any permanent objects which will help you on your way back. It is no use noticing these objects from the front only, because they will look quite different when returning, so when going forward you must look around and see how the same object appears from behind.

2. **Stars are a good guide**, but men need considerable training to do successful work with the stars, outside of the north star. Officers when training scouts should take the time to give them an idea of the principal stars and their declination, as it will prove of great value.

Stormy and cloudy nights prevent their use.

3. **The compass** is the only positive means of shaping a course to the objective and returning to safety, and too much compass work in training can never be done. Keep them at it, and use, if possible, compasses which have personal errors, in training, so that it will become a habit with them to check their compass before they leave on a patrol.

A compass with luminous points is necessary in night work, and must never be carried in a wrist strap. The best place is on a lanyard around the neck, with the compass in a pocket or the neck of the shirt. Then there is no danger of the enemy spotting a scout by his luminous wrist compass when he is crawling between the lines.

Instructions as to local attraction must be given the scouts. Should they be wearing a steel hat they must remove it and place it to one side before shaping their course; otherwise the com-

pass is useless. The same applies to rifle, revolver or other articles which would act as a deviation.

Scouts must keep in communication when on patrols. This is very difficult on a dark night. It is hard to lay down a definite rule of making sure communications between the different members of the patrol. The only sure guide is, you should never lose touch and sight of the man next to you on extremely dark nights. On other nights you are safe so long as you can see him. There are other methods, such as a jerk line or string; but it is liable to get fastened in barbed wire and a dozen other things which makes it unreliable as a means of communication.

Walk and Crawl.

One of our greatest scouts and big game hunters once said that very few people could walk properly, and he was quite right. The ordinary man goes pounding along, but a good scout puts down his feet quietly and feels where he is going to put them before advancing another pace.

There are three ways to crawl. First on the hands and knees. A scout can go forward quite a long way like this at times, and as he gets nearer you want to get down flat and you will then get your elbows and knees into action, and finally when quite close you want to use simply your hands and toes.

The men must also be taught how to crawl backwards and to turn around in a small space without showing a bulky figure.

Reconnoitering and Fighting Patrols.

Reconnoitering patrols are sent out to obtain information, and fighting patrols are sent out to kill or capture the enemy. There are many occasions when it is necessary to separate fighting and reconnoitering patrols. Reconnoitering patrols

must do their work without being detected, if possible, and in order to return with the information, etc., they must avoid fighting if possible. A patrol of this nature should be as small as possible, taking into consideration their task.

Their Work and Actions.

1. The movement must be carried out with some definite object in view, and every man in the patrol must be in full possession of the knowledge available of the objective.

2. Movement as a rule should be slow, gradual, and sometimes by bounds from cover to cover.

3. All movements must be carried out according to the first principles of protection, i. e.: (1) advance scouts; (2) flank scouts; (3) main body scouts; (4) rear scouts.

4. All must have full knowledge of other friendly patrols.

5. All must be fully informed of the hour and point of starting and returning, and the place to which they are to send their reports.

6. All must be fully trained and informed in the giving of special signals.

7. Ground carefully and constantly surveyed by day, over which they are to work by night.

8. Scouts should not be sent on patrol more than three nights out of four in fine weather and two nights out of four in wet weather.

9. Scouts should never be on patrol for more than two hours at a time, in cold and wet weather one and a half hours.

10. No patrol should be sent out by a battalion unless at least 25 per cent of those taking part are qualified scouts.

Remember.

- (a) To lie down and keep motionless the moment flares are sent up.

- (b) The safest time to move is immediately a flare has gone out, i. e., before the enemy's sight has recovered from the effect of the flare.
- (c) A scout is most conspicuous to the enemy when about 10 yards from his wire. This is where most of the flares drop, and the stakes in the wire entanglements are too far away to be of any cover.
- (d) To try and find a shell hole in which to take cover when not on the move.
- (e) To observe points when advancing which will act as guides when returning.
- (f) To turn around without raising yourself.
- (g) Scouts are easily seen when returning.
- (h) To be as cautious when returning as advancing, because when the scouts are near hostile wire enemy patrols may have taken up a position behind them.
- (i) Scouts of one patrol should not all be on the move at one time, as men cannot listen and observe efficiently then.
- (j) The best way to crawl without being observed is to make use of the elbows rather than the knees.
- (k) To have a Mill's grenade always handy, and, it must be added, to pull out the pin before throwing.

There are in addition several points which apply particularly to each of the two types of patrol.

1. Reconnoitering Patrol.

- (a) The number of men in a patrol must depend on circumstances, but the main object is to obtain information without detection, therefore the smaller the patrol the better. Men without fear may work more efficiently by themselves, but this class of men are few and far between.

DIAGRAM.

PLATE NO. 21

To show the part taken by SCOUTS in a local Trench Raid.

G. Scouts acting as left hand flank guard.

H. Scouts acting as right - - guard.

I.-I. - I. Scouts as a covering party, to fire at the enemy should they counter-attack over the top from the second line trenches.

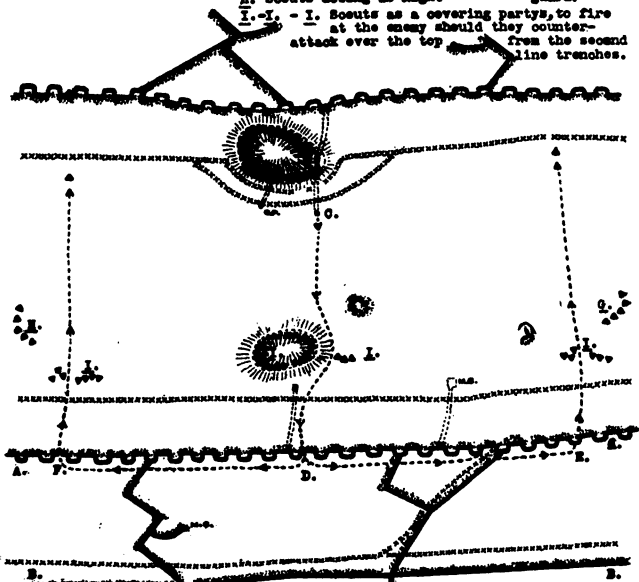

A-A. Enemy's Front Line Trench. D. Point of entrance.

B-B. Support - E. - - - exit left hand party.

C-C. Route Taken by Raiding party. F. - - - - - right

G.S.A.C.

- (b) Equipment to be light as possible. Face and hands blackened.
- (c) Every scout should be armed with two Mill's grenades and either a revolver or knobkerry. The revolver without doubt is far more serviceable than the rifle and bayonet, when going out for information without detection.
- (d) Reconnoitering patrols should never fight, except in self defense, and never in the enemy's half of "No Man's Land". Get away by all means.
- (e) It must be remembered that the use of revolvers, rifles and grenades discloses to the enemy the whereabouts of the patrol. These weapons should therefore be used only (1) where there is a certain target; (2) the patrol can reach the trench quickly and safely.

2. Fighting Patrol.

- (a) Again the number of men depends on circumstances. A patrol may be composed of any number from eight to 50 men.
- (b) The whole or part of the battalion scouts may combine to form a fighting patrol, in other words, a picked platoon. In either case it is essential that a patrol should be complete as a unit so that the men all know and have confidence in one another.
- (c) A fighting patrol should take up its selected position as soon after dark as possible. The most suitable position is one containing a large number of shell holes, and where the enemy patrols are likely to be encountered. When the position is taken up, all movements

should cease, for it is impossible for a large fighting patrol to move about without being discovered by a small hostile party.

- (d) In a trench raid, scouts will be best employed in—
- (1) Reconnoitering the trenches chosen for the raid, and showing the point of entry, exit, etc., to the officers and non-commissioned officers who are to carry out the raid.
 - (2) Act as guides, flank guards and cover party during the raid.

When a patrol is sent out for the purpose of bombing a sector, post or machine gun emplacement, always leave a covering party of scouts in shell holes about 20 yards from the enemy's wire. Two men should throw two grenades each, the levers of all four grenades being released at the same time. As soon as the grenades have been thrown the two men immediately rejoin the covering scouts and remain there until all hostile machine gun fire has ceased.

- (e) The equipment of scouts for fighting patrols should be the same as for reconnoitering patrols, with the addition of a certain number of rifles and bayonets. Owing to a small number taking part, they should in addition wear some distinctive mark.
- (f) Each man should carry three grenades, in addition to his rifle or revolver.

Schemes for Training in Patrol Work.

It is rather difficult in this branch of the intelligence section's work to find schemes which will enthuse the men with interest and keenness. The difficulty arises from the fact that training in patrol

work must be carried out in a limited area. In order to train scouts for night work during daylight, goggles with black glasses will be found very useful. Working with these on, objects will appear to the scout as if they were working in the dark, while at the same time the instructor can observe mistakes.

Demonstrate the various methods of crawling, both ahead and backwards. Turning around while lying fully extended on the back and stomach.

Demonstrate the various formations used in patrol work (see diagrams). When these formations are fully understood, have them practice them both by day and night.

Secure two opposing lines of trenches about 150 yards apart, with their respective entanglements, etc.; this can form the training area for patrol work, and can be used to practice schemes on.

Place sentries in one set of trenches and send your patrols out from the other side. Have them return in a certain length of time, with all the information they can get. Your sentries should move about, fire an occasional shot, talk in a low tone of voice and otherwise conduct themselves as if they were actually on the firing line. The patrols should be instructed to locate the sentries, and on their return have them show you on the trench map where they were.

In case of a strong point you will find it a tendency of scouts to go straight for the center, where they would not be able to find out much information which you want. The best method of getting information about a strong point is to send scouts around the flanks and in some cases right to the rear behind the point.

In all training of scouts the one essential thing is to make them keen and keep a high standard of morale, and to do that they must be well looked after and given certain privileges. You must also make his training interesting.



CHAPTER V

Reports—Messages—Orders

Reports and Messages.

With Examples of Different Types.

Reports and messages should always be written in a clear hand; and transmitted **at once** to the officer or whoever they are intended for, otherwise information that would have been of the greatest value would be useless, through arriving too late to be of service. Reports should contain only reliable information that the sender knows is correct and must be stated in figures or numbers, where the strength of the enemy's forces or equipment is the information desired. Don't exaggerate or use indefinite statements like "a great many" or "large lake" or "part of our party".

Negative information is very often of as much importance as though the enemy had actually been seen, and in a case where a scout or observer has been sent to examine a certain piece of country, a report of a negative nature will at once give headquarters information of the greatest value.

There are several general points about all reports and messages which if well remembered will always make the report concise and at the same time fully intelligent to the officer receiving same. He will also be able to judge by the framing of the report just how much faith he can put in the written message, because it is only a thoroughly trained man in writing reports who sends them in properly constructed. Further, a man must be thoroughly trained in observation and scouting to be able to gather the information for a written report. Consequently, should the report or message be constructed properly, the

chances are that the man who wrote it was fully alive to all the information he should get.

Rules to be followed in reports and messages:

(Title of one in use by sender)

Reference map.	Officer's or corps name.
Sheet number.	Battalion or brigade.
Scale.	Senders' message number. Date.
	In reply to message state number of that message

- 1.
2. The information is then to follow, under numbered paragraphs, each subject being under a separate number.
- 3.
- 4.

Place message was written (map location if in field). Time message was dispatched. How it was sent.

Signed by sender.
Rank and appointment.
The corps he belongs to.

To avoid mistakes and to form a standard system of writing messages and reports, certain details must be fully understood and instructed to the men who are concerned with this branch of the service. All important communications should be sent in by more than one means, as orderlies and runners are often lost while enroute, are hurt or some accident occurs which will stop three out of four copies. In sending in a number of copies to one place, number the copies, see the sample messages and orders which follow.

Rules as to how to report.

- (a) **Write** clearly and concisely.
- (b) **Avoid stating** anything of an indefinite nature.

- (c) **The hour must** be followed by "A. M." or "P. M."
- (d) **Names of places** and persons must be in BLOCK CAPITALS.
- (e) **A night** will be described as "night of 18-19 August".
- (f) **If a map** is referred to, position of places in map location like "building at A. 16.b. 20-40."
- (g) **Terms "right" and "left"** are used in describing a river bank, or flank of the position, a river bank when looking down stream, and a position when facing the enemy.
- (h) **Units are described** by their army list abbreviations.
- (i) **Compass bearings** are always true bearings.
- (k) **In mentioning the time**, troops reach a certain place, the head of the main body is meant.
- (l) **Avoid carelessness.**
- (m) **In urgent cases** don't hesitate, write a short message and get it in, time is everything to get results.
- (n) **If there is time**, send in a sketch, when reporting on a position. It makes everything clearer.
- (o) **Avoid the indiscriminate** use of military terms.
- (p) **Do not use an indelible pencil**; the least trace of water and the message is ruined.

Messages and reports are frequently mixed up with "orders" (operation orders). The two forms are entirely different and distinct, and both should be carefully committed to memory.

Report from Scout Sent Out to Certain Point to Locate Enemy.

Ref. Map Aldershot (so.) To Captain J. T.
 1 O. C. "A" Co'y—Bat.
 Scale ——— C. I.
 10.000 Brownlee Hotel,
 From G 14 c 40-70. Hants.
 No. 4
 4/8/17

1. On arriving here 5 P. M., discovered enemy infantry marching on road **Rockin-Sumas** in W. direction; took 7 minutes to pass cross road G 26 c 25-30; estimate number at 1400 men; had no transport.

2. Small group (6 men) on hill G 22 b 40-50 have range finder and heliograph. Men wearing uniform of — guards. Three are working with entrenching tools.

3. Will remain here for further instructions.

6:15 P. M. C. G. Dunn, Sergt. Scout.
 Sent by Pte. Brown, i/c No. 2 group scouts.
 Runner. — Battalion C. I.

Scout is sent message to proceed to certain area and see if any of the enemy are there. (Sends back a negative report as follows.)

Ref. Map Aldershot (so.) To Captain J. T.
 1 O. C. "A" Co'y —
 Scale ——— Bat. C. I.
 10.000 Brownlee Hotel,
 From G 11 b 80-95. Hants.
 No. 5
 5/8/17
 Your No. 23

1. Can find no enemy in square G 12 a 70-60,

G 12 b 80-30, G 18 b 50-50, G 17 b 40-60; spent entire night 4/5 on this ground.

2. Arrived here at 5 A. M. Will wait further orders at ruined mill G 11 a 20-80.

5:15 A. M.

Sent by Pte. Horne,
Runner.

C. G. Dunn, Sergt Scout,
i/c No. 2 group scouts,
— Battalion C. I.

Road Report from Sergt. in Charge of Scout Patrol Party.

Ref. Map.

Tontine Service Sheet
No. 6.

Scale 1 mile = 1 inch.
From N 21 c 30-20.

To Intelligence Officer,
— Battalion C. E. F.
Rogers Camp, E.

5/7/17.

1. **Started on road Milforte-Soutnin** at D 20 b 80-20; moved south for 400 yards, then S.W. for distance 2 miles; then S. for $1\frac{1}{2}$ miles, then W. for $\frac{1}{2}$ mile. Road throughout is second class, in good state of repair.

2. **Road has gradual down grade** for first $2\frac{1}{2}$ miles where the river **Cascade** crosses, and the remainder of road to point N 21 c 30-20 runs up grade at an average of $\frac{1}{10}$ the first 200 yards from river being on a grade of $\frac{1}{20}$.

3. **No fences, ditches or other obstructions** prevent moving off the road at any point until after river is crossed; after river **Cascade** is crossed several deep cuttings have been made in the first 450 yards, to make the grade of the road better.

4. **The country** on both sides of the road has light growth of fir trees, which would prevent transport from using the sides of the road; this growth also prevents any view of country to E. or W.

5. **The bridge crossing Cascade river** has been destroyed; the river at this point is 500 feet wide,

and from 12 to 15 feet deep in the center; the current runs about 3 miles per hour. In looking for a boat or some other means to cross we found a small ferry tied to the bank, 700 yards up stream on the opposite side of the river. This ferry cannot be seen from road crossing, being around the first bend. We made small raft and crossed and found ferry measured 4 feet deep, 20 feet wide and 55 feet long. It is in good order. It will require 25 or 30 men to launch her from shallow water where she now is to the deep channel, a distance of 20 yards. The steel ferry cable is lying in an old shed 200 yards inland from the ferry.

6. Scouts went half mile above and half mile below the road crossing, but could find no other means of crossing river.

7. There are no fords.

8. While party was crossing river on raft, rifle No. 177678 was accidently shoved overboard and lost.

9. I have left Corpl. Brown and two men to guard ferry until further instructions from you.

10. We have found no indications that the enemy are in this area, with the exception of the tracks of three horses which lead down to road crossing and then turned back S. on road. I would judge these tracks to be at least four days old.

11. Enclosed find sketch of road, with particulars of topography noted.

12. I will remain at high ground N 21 c 30-20 with my party until we receive further instructions from you.

4:30 P. M.

Sent by Pte. O. James,
Scout and Runner.

J. M. Jones, Sergt.,
I/c Scouting Patrol.
— Battalion C. E. F.
5/7/17.

**Observers' Report of Operations of the Enemy,
Etc., Etc., (on printed form).**

Sniper's or Observer's Report.

Ref. Map Trench No. 154 Battalion, —th Canadians
1 Snipers or observers on
duty.

15840

Time, 7:15 p. m.

Date, 5/7/17.

1

2

3

Post. 4

5

6

J. P. Summer, Corpl.

O. Blank, Pte.

**Information
About
Enemy.**

At 9:45 A. M. a working party was seen in enemy's first line trench, renewing parapet about C 18 c 20-70. There are two new loop-hole plates and what looks like a machine gun emplacement at about C 18 c 70-60.

At 10:30 A. M. working parties were observed in hedge at **Cilleau Cross Roads** and in the house with the red roof at about C 18 c 20-00. They were dispersed by trench mortar fire at 10:45 A.M .

At 11:50 one of our aeroplanes (Bristol scout type) passed over from rear, course flying 300 degrees magnetic. Shortly after dense black smoke was seen on magnetic bearing 303 degrees; there was also considerable anti-aircraft gun fire. Did not see our plane return.

At about 4:00 P. M. our trench mortars opened fire on **Red Roof Inn**, C 18 d 50-20, to disperse a working party; the fire was evidently accurate, as we saw several ambulances come

**Information
About
Our Lines.**

up to cross road at **Redout Cross Road**, G 30 a 25-60; they remained there for 30 minutes and retired. The enemy returned our fire with about 125 "Whizz-Bangs" and some H. E. shells; this did very little damage in our sector of trenches.

Daylight became bad for observation today at 6:45 P. M. Wind light today from true bearing 165 degrees.

Our new snipers' post at B sector 154 progressed well all day; men are now filling old trench 50 yards to right of post with surplus earth; the steel plate for post arrived at 4 P. M.

The officer commanding battalion visited our post at 12:15 noon.

Pte. Blank was shot by sniper who fired from magnetic bearing 260 degrees and our snipers on left flank are trying to draw his fire again, with dummy, in order to get his bearing from their post. Did not succeed in doing this until dark, when bearing secured leads us to think he must fire from two loop-holes; we will try him again in morning.

Remarks.

Nil—

Prisoners.

At 12:50 P. M. our observers at A 28 a 70-00 captured an enemy artillery private, with written message (enclosed) for an officer at **Wilford**. Private claimed to be lost while on way from battery No. 55 behind hill at A 30 a 10-10 to their artillery headquarters, which he informed us was at **Wilford**, in the **Baale Mou Inn**. He further stated that in addition to battery No. 55, battery No. 53 was stationed at about A 23 b 80-20 and battery No. 51 was stationed about B 13 a 30-30. He also stated that the artillery officer who dispatched him, told him to take the road that led him into our lines, and that personally he did not know the road or the country. He further said that the batteries above mentioned were to change position after the noon hour or about 1:30 p. m. On being questioned as to where their medical headquarters were, he informed us at **Wilford** with artillery headquarters. On being questioned where their ammunition parks were located, he only knew where his own battery had theirs; this was at about B 15 c 30-90. This information was sent at once by runner to our battalion headquarters.

At 1:15 P. M. a mounted enemy artillery officer and his orderly were captured by two of our scouts who were coming up from the rear on motorcycles, and on being taken prisoner and brought to my observation post, stated that he had lost his way; would give me no further information except his name, rank and unit. I removed his arms and in his map case, which was strapped under his saddle blanket, I found the map locations of two batteries which I at once dispatched to our artillery headquarters via motorcycle scout, reporting same to battalion headquarters by

runner. Prisoner was sent to brigade headquarters under escort.

Weather.

The day was foggy, observation low and poor, a light southerly and south-west wind prevailed.

Many of the enemy's artillery observers or scouts could be seen on the distant sky line at any time of the day; also a few mounted men on the right flank.

Four enemy scouts were observed at A 22 a 30-70 apparently sketching. One of them appeared to be an officer: Our snipers failed to get them. Telephone or "buzzer" connection were also run into this point from A 26 a 90-10.

Sketch Map.

Attached sketch map shows in detail by means of a red dotted line our line of scouts and outposts.

Blue dotted line shows enemy's outpost line as we located it.

Blue diamonds show enemy artillery positions as located by our observation posts.

(Signed)

Lieut.

Officer I/c ——— Battalion

Intelligence Section.

2 Copies 13th Brig. H. Q.

1 Copy ——— Battalion H. Q.

1 Copy ——— Artillery H. Q.

1 Copy File.

Forwarded by runner.

5:45 A. M., 2/3/17.

**Example of an Operation Order—For Comparison
as to Construction with Reports and Messages.**

“B” Canadian Infantry Battalion.

OPERATION ORDER NO. 9.

Reference Map. Copy No.

Aldershot north and south. 15/7/17.

Scale, 1 inch to 1 mile.

1. **Information.** The Germans are holding the line **Tousbury Hill, Clover Pit Hill** and the **Tyne**, which is apparently a forward line to their system of trenches on the **divide**. The Canadian corps is advancing northward to make good the line of the road **Averley Abbey—The Pands—two Mill Common**. The “B” battalion has been allotted the objective from the point where small track crosses this road 200 yards south of the second letter in **Pands** to 0.408, 425 yards to the southeast. At the same time “A” battalion—Canadian infantry brigade—is attacking on the right flank, and a battalion of the — Canadian division on the left flank of the battalion has a line drawn from the junction of the **White Roads** 200 yards northwest of the T of **Tumuli** to the point where the small black track crosses **Pands-Twomill Road** just south of the A in **Pands**. The right flank is from the first 2 of 0.242 to 0.408 on the **Pands-Twomill Road**. The Canadian outpost line at present occupied runs along north hedge of the wood 300 yards north of the word **Tumuli**.

2. **Intention.** The “B” battalion will attack the enemy’s positions, crossing the outpost line at 10:30 a. m.

3. **Distribution.** Capt. M. with D. Co.
Capt. T. with C Co.
Capt. Z. with B. Co.
Capt. H. with A.Co.

"A" and "B" companies to form the firing line furnishing their own supports. "C" company will act as supporting company. "D" company will be held in reserve.

4. **Objectives.**

"B" company will make good the hill with the two **Tumuli** on it at the Y of **Tumbury Common**. "A" company will work around the right flank at the same time keeping behind "B" company, and when "B" company have gained their objective will assault the hill on the right flank at the second L of **Clover Pit Hill**. When this has been gained "B" company will advance until somewhat ahead of "A" company and the line will move forward to the southern edge of the road from 408 to the trail on the left flank of the objective. The line will then move forward and occupy and consolidate the high ground to the north of the road. The dividing line between the two companies is the bottom of the draw, and the ditch running up to the end of the fence west of the house west of 0.480.

5. **Covering
Fire.**

The brigade machine guns will support the advance with machine guns placed on the hill on the right center of the outpost line until the two first objectives are captured and the enemy has retired into the woods, when they will advance forward with the reserves.

6. **Communica-
tion.**
Lieut. K.

A line will be run from brigade headquarters at the **Half Way Inn** at **Tirponhill** to the hill at right center of outpost line and will be run forward to the first two objectives when

they are gained, following up on both flanks to the final objective.

7. **Ammunition**
R. S. M. There will be an ammunition dump at the right center hill of outpost line and the mules will be held there in readiness to be rushed forward on capture of objectives.
8. **Dressing Station**
M. O. Advanced aid post at hill right center of outpost line.
9. **Synchroni-
zation.** With the adjutant at **Report Center** at 9:30 a. m.
10. **Reports.** To hill at right center of outpost line thence to hill just south of the second L of **Clover Pit Hill**, then to cottage 100 yards east of left flank objective.

(Signed)

Lieut. Colonel.

O. C. "B" Battalion Canadian Inf.

Time, 8:30 a. m.

Issued by Runner.

Copy No.	1	O. C. Battalion.
" "	2	O. C. "A" Coy.
" "	3	O. C. "B" Coy.
" "	4	O. C. "C" Coy.
" "	5	O. C. "D" Coy.
" "	6	Communication Section.
" "	7	Intelligence Section.
" "	8	M. O.
" "	9	R. S. M.
" "	10	G. O. C. —th Canadian Inf. Brigade.
" "	11	—th Canadian Artillery Brigade.
" "	12	—th Canadian Brigade Machine Gun Co.
" "	13	—th Brigade Canadian Field Ambulance.
" "	14	O. C. "A" Battalion.
" "	15	O. C. —th Battalion —th Canadian Div.
" "	16	16-17-18 to records files.

Signalling.

The methods now in use in the army all depend on the ordnance Morse or dot and dash alphabet, whether the signal be transmitted by flag or other means, such as lamps, heliograph or field telephone (The latter under service conditions at the fighting front is practically only employed as a telegraph for signalling, and never for spoken messages except under the most urgent circumstances in the case of ground circuit; metallic circuits are considered safe.) In fact the field telephone has almost entirely superseded the system of signalling with flags.

While the semaphore system is very useful, and is still retained in the navy, it certainly simplifies matters in the army to have one standard system only, wherever the signalling medium may be. Both the army and navy now only employ the "long" or full numerals to avoid any possible confusion. Certain technical differences occur in the Indian army system, but they are not of such nature as to present any obstacle in the way of Indian trained men from working with home trained signallers.

When transmitting Morse signals by flag, a signal flag (instead of two flags, as in the case of the semaphore system) is pivoted in both hands held at a ready position (at about 45 degrees to the horizontal over the left shoulder of the signaller). All signals are made from this ready position. The pole of the flag is so held that the hands come in front of the sender's mouth, and so that he can see beneath the flag. From the ready position, the pole of the flag being pivoted in the right hand, the flag is moved across the body to a corresponding angle on the opposite side, and is then brought back again to the first or ready position. This movement represents one dot. The dash

signal is made by bringing the flag across the body until the pole is just below the horizontal, and then back again to the ready position.

In the diagram the Morse international code is given. The alphabet only differs from the army modification of the code in that all the accented letters and "ch" are omitted in the latter. There are, however, considerable differences in the punctuation signs and signals, so they are given separately.

Morse International Code.

a	— — — — —	h	— — — — —
ä	— — — — —	i	— — — — —
á or å	— — — — —	j	— — — — —
b	— — — — —	k	— — — — —
c	— — — — —	l	— — — — —
ch	— — — — —	m	— — — — —
d	— — — — —	n	— — — — —
e	— — — — —	ñ	— — — — —
é	— — — — —	o	— — — — —
f	— — — — —	ö	— — — — —
g	— — — — —	p	— — — — —
	q	— — — — —	
	r	— — — — —	
	s	— — — — —	
	t	— — — — —	
	u	— — — — —	
	ü	— — — — —	
	v	— — — — —	
	w	— — — — —	
	x	— — — — —	
	y	— — — — —	
	z	— — — — —	

Figures.



Short Figures.

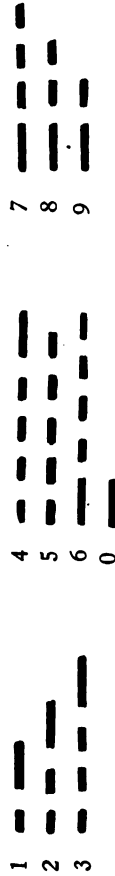

Punctuation.

(.)	— — — — —
(:)	— — — — —
(.)	— — — — —
(:)	— — — — —
(?)	— — — — —
(")	— — — — —
(l)	— — — — —
(')	— — — — —
(-)	— — — — —
(/)	— — — — —
(=)	— — — — —
(— — — — —
)	— — — — —

Various Signs.

Call	— — — — —
Understood	— — — — —
Error	— — — — —
End of transmission +	— — — — —
Invitation to transmit	— — — — —
Wait	— — — — —
"Received" signal	— — — — —
End of work	— — — — —
Underline	— — — — —

Spacing and Length of Signals.

(1) A dash or bar is equal to three dots in duration of time or space; (2) the space between the signals which form the same letter is equal

to one dot; (3) the space between two letters is equal to three dots; (4) the space between two words is equal to five dots.

It will be noted that this system has a harmonic or time basis which is decided upon by the time required for a dot; intervals between letters or words are essentially definite multiples of the dot time; hence if careful attention is paid to the timing, a very clear system of signalling is available.

It must also be observed that in the International system the dot of former practice has been replaced by a short bar, as being more consonant with the time basis of the present-day system.

Army Punctuation Symbols.

(Note.—These differ from the Morse International Code.)

Full stop (.).....	● — ● — ● —
Break signal or fresh line	— ● ● ● —
Apostrophe (').....	● — — — ●
Hyphen (-).....	— ● ● ● —
Exclamation (!).....	— — ● ● — —
Oblique stroke (/).....	● — ● ● —
Horizontal bar (—).....	— ● ● — ●
Interrogation (?).....	● ● — — ● ●
Inverted commas (")...	● — ● ● — ●
Brackets ().....	— ● — — ● —
Underline	● ● — — ● —

Miscellaneous Army Signals.

General answer	—	
Erase (part of message or a word)	● ● ● ● ● ● ● ●	
Obliterate (whole of message)....	● — — ● — —	
Stop sending (PP).....	● — — ● ● — — ●	
To indicate block capitals (Z)....	— — ● ●	
Repeat (IMI)	● ● — — ● ●	For checking purposes
Word after (WA).....	● — — ● — —	
Word before (WB).....	● — — — ● ● ●	
Go on or spell out (G).....	— — ●	
End of message (VE).....	● ● ● — ●	
Received correctly (Rd).....	● — ● — ● ●	
Wait (MQ)	— — — — ● —	
Call or station call.....	● ● ● ● ● ● ● ●	
Symbol used between whole numbers and fractions (MM).....	— — — —	

“Code” Time (as used by all army signallers) is the method adopted for signalling time, and is the most expeditious system yet discovered.

The twelve hours from 1 in the afternoon to midnight, and from 1 in the morning to midday, are denoted by the letters A to M, omitting J. Thus:—

A denotes	1	E denotes	5	I denotes	9
B “	2	F “	6	K “	10
C “	3	G “	7	L “	11
D “	4	H “	8	M “	12

The same letters stand also for the twelve periods of 5 minutes. So A stands for not only 1 o'clock, but 5 minutes past any hour. And B stands for not only 2 o'clock, but 10 minutes past any hour. And C stands for not only 3 o'clock, but 15 minutes past any hour. For example, BC would therefore mean 2:15 o'clock.

The intermediate minutes are indicated by the letters R, S, W, X, so that MR indicates 12:01; MX means 12:04; MAR means 12:06.

The letters “A. M.” and “P. M.” are always entered and sent in conjunction with the above.

Prefixes.

Prefixes form a very important part of the curriculum of the signaller, and are consequently of interest here.

Messages are **prefixed** to serve the purpose of giving precedence of dispatch to those of highest importance, also to indicate whether they are to be transmitted or delivered in the case of station work.

If a message contain X it is to be transmitted; if S it is for delivery.

Prefixes are **always** signalled at commencement of message.

The following are the British army prefixes arranged in order of precedence:—

Messages to be Delivered at Receiving Station	Messages to be Transmitted at Receiving Station	Class and Remarks
{ S O S }		Take precedence over all, and to receive immediate attention.
{ G A S }		
{ Z E P }		
D S	D X	Signal service messages requiring immediate attention.
S B	X B	Messages "O. H. M. S." marked "Priority".
S G	X G	Signal service messages.
S M	X M	Messages "O. H. M. S." not marked "Priority".
S	X	Private messages.
S P	X P	Press messages.

CHAPTER VI.

Trench Warfare

Semaphore Signals

This alphabet is now only employed in the navy and mercantile marine.

Wireless Telegraphy.

The wireless system is used on most of the larger and more powerful aeroplanes and seaplanes, but up to the present time has not come under the instructional work of the intelligence section and their work in the field. If they master the telephone, "buzzer" and single flag work by the Morse system of signals they will be able to do all the duties of signalling that will be required of them. Signalling is a special part of army work and is handled almost entirely by the unit and brigade signal sections.

Sniping and Observation.

A good system of sniping and observation must be maintained in trench warfare, as it is of the greatest importance that the enemy's lines be under constant observation for any new work he undertakes, changes in his line, keeping the enemy's snipers in check, and for the purpose of inflicting as many casualties on his forces as possible. Consequently, every battalion should have in their intelligence section as many fully trained and intelligent snipers and observers as their establishment will allow.

Some of the most important items towards maintaining a successful system are:—

- (a) The careful selection and training of the observers and snipers.

- (b) **Good Discipline**; the men will conduct themselves with a great deal less carelessness when at work.
- (c) **Properly selected sites**, well made and concealed posts or loop-holes.
- (d) **Careful attention to seeing** that all parts of the enemy's line come under observation.
- (e) **Care of rifles**, glasses and other equipment.
- (f) **The use of disguises**, masks, dummies and other devices.

Selection and Training of Men.

Men selected must be intelligent and well educated, as well as being first class shots. They must have thorough training in the art of observation and method of describing everything they see, as they are the eyes of the battalion.

In the training of observers and snipers, some of the most important things they should be taught, and taught well, are:—

- Shooting at moving objects.
- Making sure of their target before firing.
- Judging distance.
- Zeroing of their telescope sights.
- Use and care of telescope sights, field glasses and periscopes.
- Use of natural cover for open warfare.
- Construction of artificial cover.
- Construction of observation and snipers' holes.
- Construction of bullet-proof loopholes of every type.
- Value of silence in their work.
- Unlimited patience.
- Art of disguising themselves and their posts.
- Writing of reports, short, clear and to the point.
- Map reading.
- Selection of proper sites for their operations.

MARKED TRENCH MAP SHOWING SNIPERS AND OBSERVATION POSTS.

PLATE NO. 23

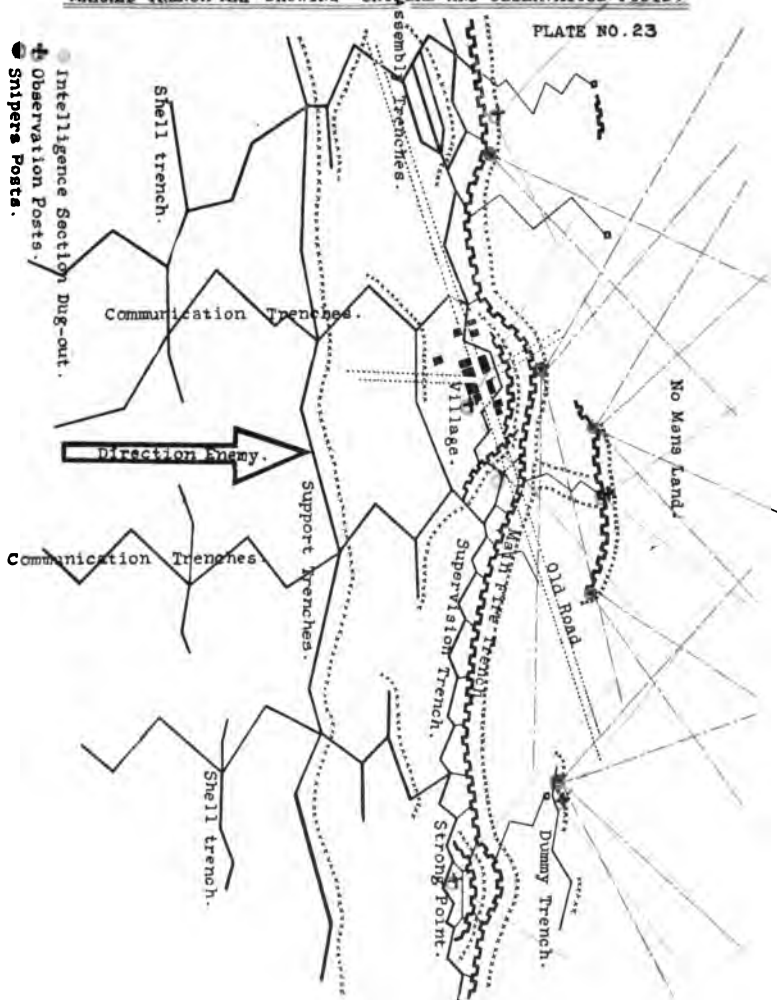

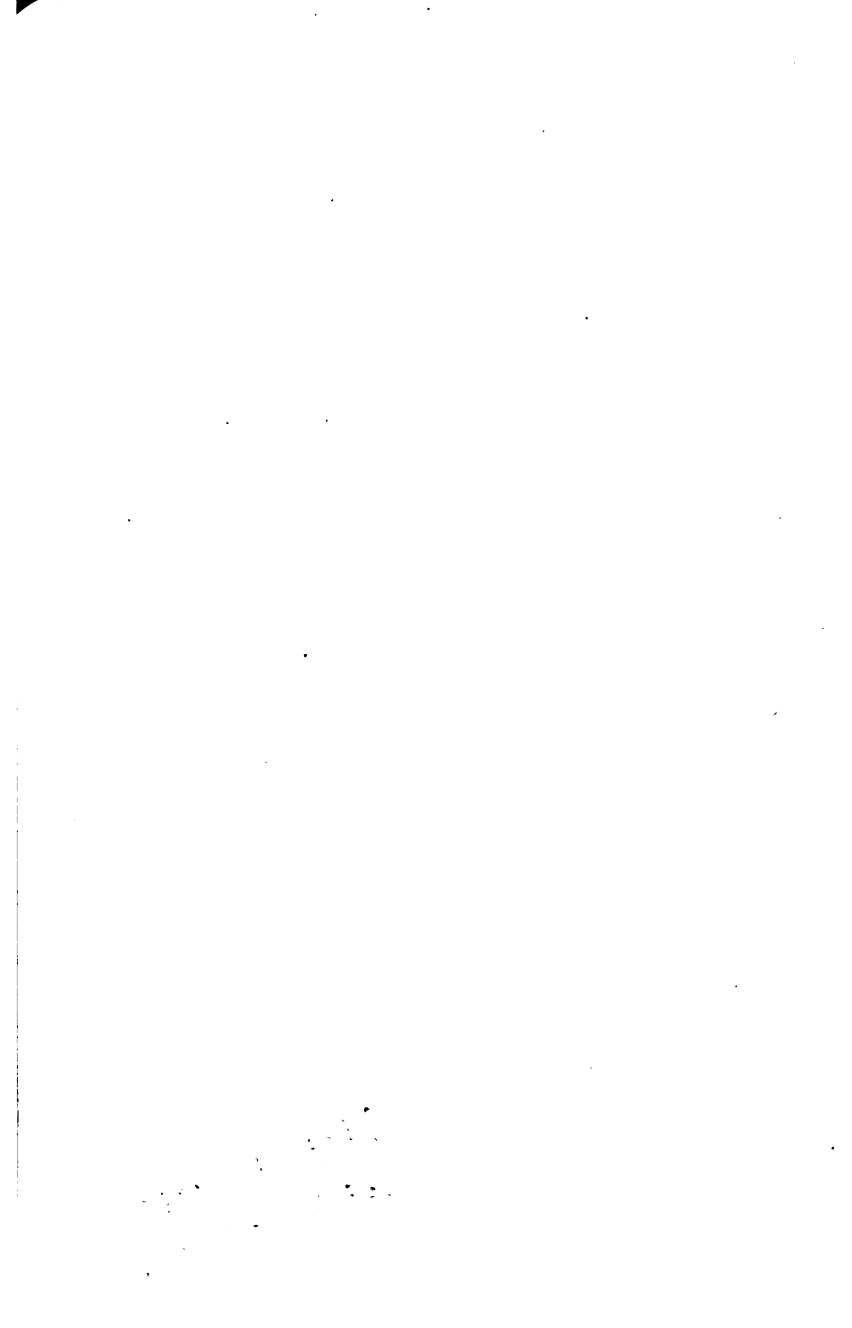

Moving silently, whispering and private signals to each other.

To **remember** that once discovered, their observation or sniper post has become a death trap.

A very important matter is in keeping your snipers and observers well informed as to what is going on generally. They should be allowed to read the intelligence reports from other units. This not only gives them good, reliable information as to the other snipers' and observers' actions and results, but has the tendency to buck them up on their own reports, and consequently make them all the keener to observe the enemy's front lines for real information. Show them the aeroplane photographs as they are sent in, and discuss with them the likely-looking places where the enemy may have been constructing new sniper and observation posts; they will then pay particular attention to these points during the day. Let any who are off duty be present when any prisoners or captured documents are being examined, and in every way take them into your confidence.

No definite rule can be followed as to the most suitable position for a sniper's or observer's post; this entirely depends on the class of fighting, nature of the country and the condition of the ground. Details like this have to be left to the ingenuity of the intelligence section. Many points which would be highly satisfactory for this work can be located in the rear of the firing line. On the other hand, "No Man's Land" should be more suitable. The best time to reconnoiter for such points is during the evening light, when the enemy cannot see any great distance, but while you can still see if the point selected is going to give you the view desired.

The building of snipers' and observers' posts so as to make them secure, hard to detect and convenient for their purpose of firing at and watching

-Plan-

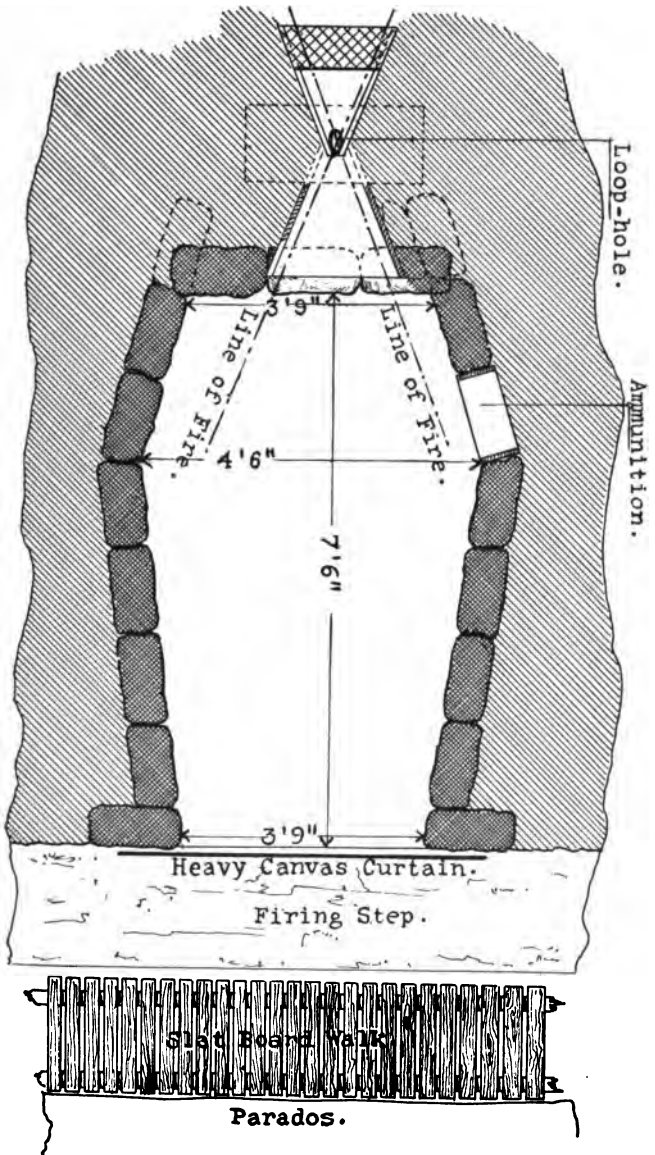

certain points, requires all kinds of practice and actual constructing before a new bunch of snipers are ever allowed to actually build them under service conditions, possibly under rifle, machine gun and rifle grenade fire. Loop-holes and snipers' holes usually have to be put into the parapet at night, and every man must know the work and how it is to proceed, as time is everything. Every detail must be finished by daylight, and the parapet left in its natural condition.

In the German trenches sandbags of various colors and shapes are piled up anyhow along the parapet, giving it an irregular outline and making it very difficult to find loopholes or to distinguish them from dummy loopholes. The irregular outline gives greater security when firing from the parapet and also makes the matter of concealing snipers posts' apertures a much easier matter. They also throw any rubbish over onto the face of the parapet, such as old timber, beams, mattresses, straw, tin cans, etc., which all make finding their snipers' loopholes a much more difficult affair.

The use of veils over the head and face, and coats of a color to match the background are often very useful. If near sandbags, an empty sandbag worn over the head, with the bagging stretched or opened slightly in front of the eyes, is an excellent disguise. If a bare earth background, a brown suit with dirt rubbed or thrown over the wearer, and against grass a suit of a corresponding color are hard to detect.

Dummy loopholes are of great value, as they draw the fire of the enemy's snipers, and it is often possible to locate his hiding place by some "ruse" of this nature.

Posts should be so arranged that the whole front of the enemy's line opposite the battalion sector is under observation and covered by at least one sniper, from daylight to dusk, each post

Direction Enemy.

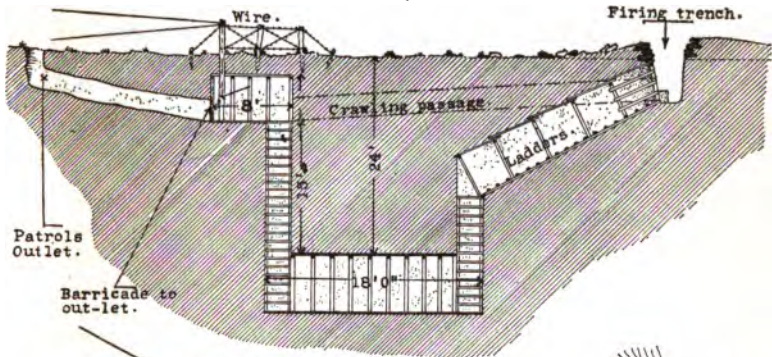

SECTION VIEW.

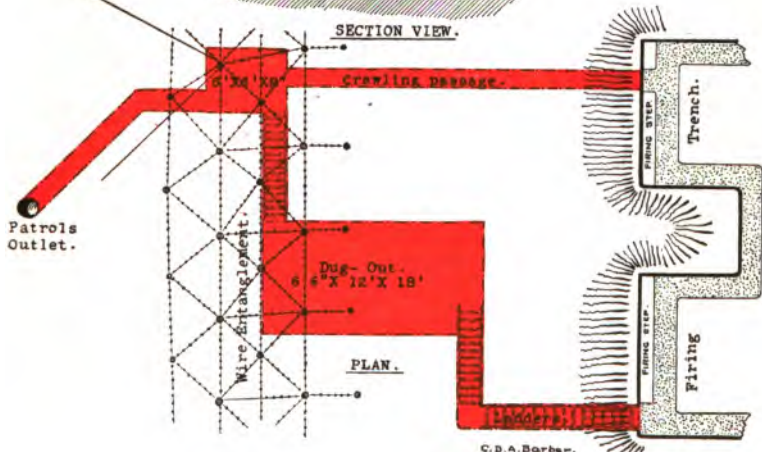

PLAN.

C. D. A. Barber.

having a definite section of the opposite trench to keep under observation.

Observers can work singly but snipers should work in pairs, one observing while the other is in readiness to fire. Four men in two reliefs should be told off to each sniper's post.

Each post should be made to send in daily a report under the following headings. A printed form is convenient.

Sniper's or Observer's Report.

Ref. Map.....	Battalion
Time	Snipers or Observers on
Date	Duty:
1.
2.
3.
Post 4.	
5.	
6.	

Information About Enemy.

(I. e., new work done, machine gun emplacements, trench mortars, snipers' posts, observation posts, new loopholes, enemy seen, place, uniform, apparent age, any enemy fired at, any evidence to know they were hit, direction and strength of wind, aeroplanes or gas, changes in wire, signs of mining, etc., etc.)

Information About Our Lines.

(I. e., casualties, what direction was the fire from, new loopholes completed, observation posts, dangerous places, broken trench, effect of shell fire, any breakage of rifles or equipment. Any other information of interest, etc., etc.).

Remarks.

(I. e., have you any suggestions or ideas to make the work more effective?)

Snipers should not be required to do any night work. The duty of constant observation during the day is quite enough, and with the cleaning and care of their rifles and equipment a sniper's time is fully taken up. Observers and scouts are detailed for night work, as a great deal of information they gather can only be secured in "No Man's Land" and only after dark.

Discipline of the best is absolutely necessary in the whole intelligence section.

When a battalion is taking over a new line, the battalion intelligence section should, whenever it can be arranged, spend 24 hours in the new lines with the scouts and snipers of the battalion to be relieved, in order to obtain all the information available and find out from them just what to expect and become acquainted with any other details that concern them.

If a line is taken over in which the enemy's snipers have been allowed to get the upper hand, the first task is the location of the enemy's snipers' posts. The enemy's loopholes should be searched for all along the parapets, together with any likely sniping places in the rear. The trees, sandbags, tin cans, broken rubbish, etc., in our trenches should be searched for rifle bullet marks which may show the direction or bearing of the enemy's snipers. Sentries should be told to try and discover from what point sniping is coming. When everything possible has been done to find the location of the enemy's snipers, a system of snipers' posts should be decided on by which every part of the enemy's line can be observed and fired on.

Fixed rifle pits and batteries are often very useful for keeping certain points and positions under fire at night, and by this means hampering the enemy's work on his wire or outlets for scouting parties, besides causing considerable loss.

Snipers and observers may have to be employed on other than their own duties and their training as special messengers and guides, bombers and Lewis gun men should not be overlooked.

In case of a raid on the enemy's trenches, or in the event of our trenches being raided, they would have their special duties to carry out, such as picking off machine gun operators, observers, officers and section leaders, and any men exposing themselves in the open. Covering their own bombers, machine gun men, consolidating parties, etc. They should all be instructed in these different duties and trained to always act on their own initiative.

The Theory of Fixed Rifle Fire.

Under the supervision of the officer, non-commissioned officers and men of the intelligence section, good, valuable work can be done both by day and night with fixed rifles. There are a number of ideas as to how these rifles should be mounted and handled, but any good plan that gives the operator the necessary elevation and traverse, to cover the desired frontage, with some means of getting his rifle accurately "set" on the compass "bearing", will give very satisfactory results.

Six or eight men in each section should be given special training for this work; it requires a high degree of accurate map reading, also considerable close work in making the necessary calculations when setting the rifle stand, for elevation, jump, drift, firing up or down hill, barometric pressure and temperature, wind, and the class of rifle and ammunition used.

The Fixed Rifle Can Be Used in Both Direct and Indirect Fire.

In direct fire, i. e., by sighting it during the day on sap heads, gaps in the wire where patrols go out and in, where damage has been done to the

enemy's wire and working parties will operate after dark, on new work the enemy is during the night engaged in, or for concentrating a close fire on a sniper's loophole or the opening of a machine gun emplacement after dark.

By indirect fire on the enemy's dumps, paths, trenches, trench tramways, cross roads, assembly trenches, or any other important point in the rear of the enemy's front line trenches where work or travel to and from the trenches, converges on a given point, would seriously hamper their operations besides causing considerable loss.

Good work can be done by the fixed rifles sighted during the day, in covering bombing, raiding and reconnoitering patrols which are sent out after dark, the fixed rifles being trained on the machine gun emplacements, or to traverse the line of the enemy's parapet, their exits in the wire and saps where patrols would come out to fight our own, or in other ways acting as a covering fire to protect our own men, should an alarm be sounded. Much of this work can be well done by means of mounting rifles in two notches cut in the opposite sides of a small box, some 14 or 16 inches wide, and having a flat place in the top of the parapet to set the box on after dark so that the rifle will be trained on the enemy's parapet line, or by the use of two stakes driven into the parapet so rifle is lined up, and by the use of luminous patches on the posts of the wire entanglement, which can be used as a guide in aligning the fixed rifles. Firing in the latter cases should only be allowed within quite close range.

Indirect firing at the longer ranges requires a proper fixed rifle stand, something on the lines of the stand shown in plate No. 25, and in addition requires experts to set the stand if any satisfactory results are to be expected. Maps and aeroplane photos have to be carefully consulted to decide

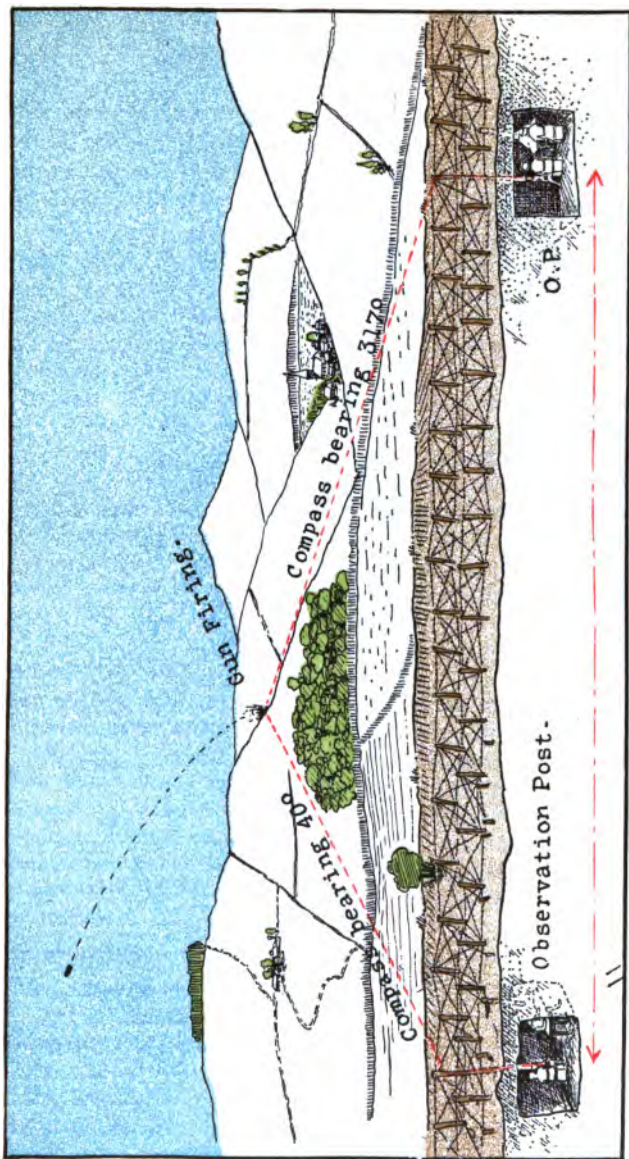

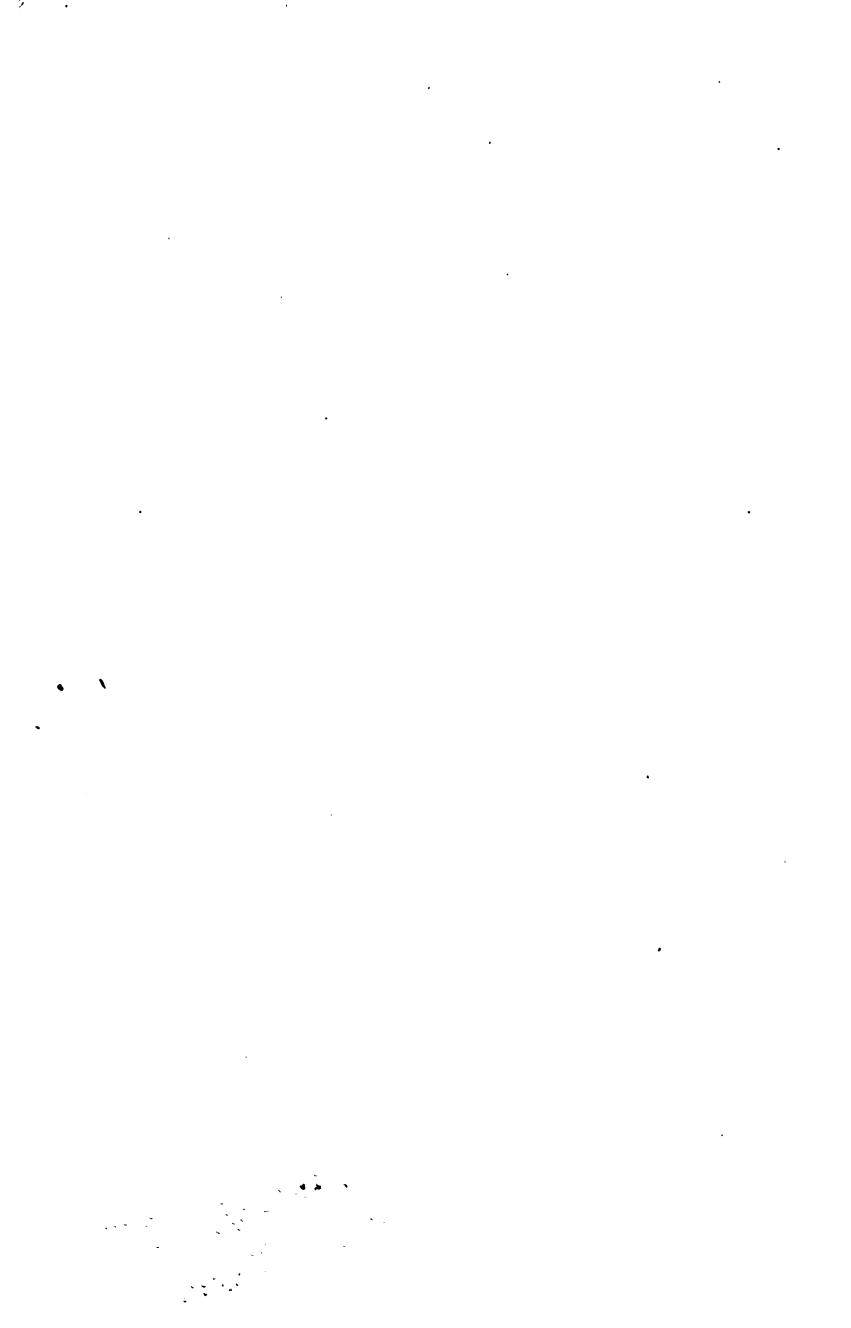

on the best point for the fixed rifle, what range would give the proper trajectory to get the best beaten zone into the desired area. A general knowledge of the angle of fall of the bullet in the last 100 yards of its flight is essential, as a guide as to deciding if a grazing or plunging fire would be the most effective. Here again the expert knowledge of map reading comes into use, as the lay or natural contours of the country are a big factor to take into consideration.

In indirect fire the first thing to consider, after the position from which the fire is to be opened from has been decided on, is the setting of the rifle rest. By referring to plate No. 25 it will be noticed that this stand is metal, so it would be almost impossible to "set" the stand correct with a prismatic compass, as the stand would set up a local attraction which would throw the "bearing" away off the proper direction. So in case a metal stand is used, a wooden sub-stand has to be resorted to which can be properly "set" by center line, with quadrant showing about 15 degrees each side of center, so that the rifle can be slightly shifted in bearing without moving the wooden sub-stand. After the sub-stand has been "set" any alteration in the bearing owing to a change of wind, temperature or other causes, can be adjusted by the hand adjustments on the metal stand, using the quadrant scale to get the difference between the new and old bearings.

Three primary forces act on the bullet:

The explosion of the powder charge, which drives the bullet forward.

The gravity, which is the natural attraction which draws all unsupported bodies toward the center of the earth with increasing velocity, and which gets into action immediately the bullet leaves the muzzle of the rifle.

The resistance of the air, which causes the velocity of the bullet to decrease in speed very rapidly.

The combined effect is to cause the bullet to travel in a curved line called the trajectory, the curvature of which becomes more pronounced the longer the range.

In plate No. 25 trajectories are shown firing at ranges of 1,200 yards and 2,100 yards, the firer and the object fired at being on about the same elevation above the datum level. In the case of the 1,200-yard range, a grazing fire has been established over a slight rise in the country, with the object of striking a junction in a road and the end of a communication trench, marked on the map dump. This trajectory was not only correct to pass over the hill and strike the dump, but during its flight (the bullet) formed two danger spaces, in one case 293 yards at the top of the hill, and another of 180 yards just before coming to the dump. Such an ideal state of affairs is very hard to arrive at, but the sketch is for the purpose of showing what could be done under such conditions of range and lay of country.

In the second case of the 2,100-yard range, the first thing to take into consideration was, could the bridge and turn in the road at the village be reached in a proper manner from the original position of the firer. In the case of trajectory B, the firer tried it out at 1,900 yards, his actual distance from the village, but found that the bullets would strike the top of the hill, and never get to the objective; by raising the sights to 1,950 yards the bullets would probably strike in the buildings themselves, but the chances are that the actual road itself would not be a very dangerous spot unless an odd bullet ricocheted down from the walls of the buildings; so the best thing to do was to move the fixed rifle back say 200 yards and fire from

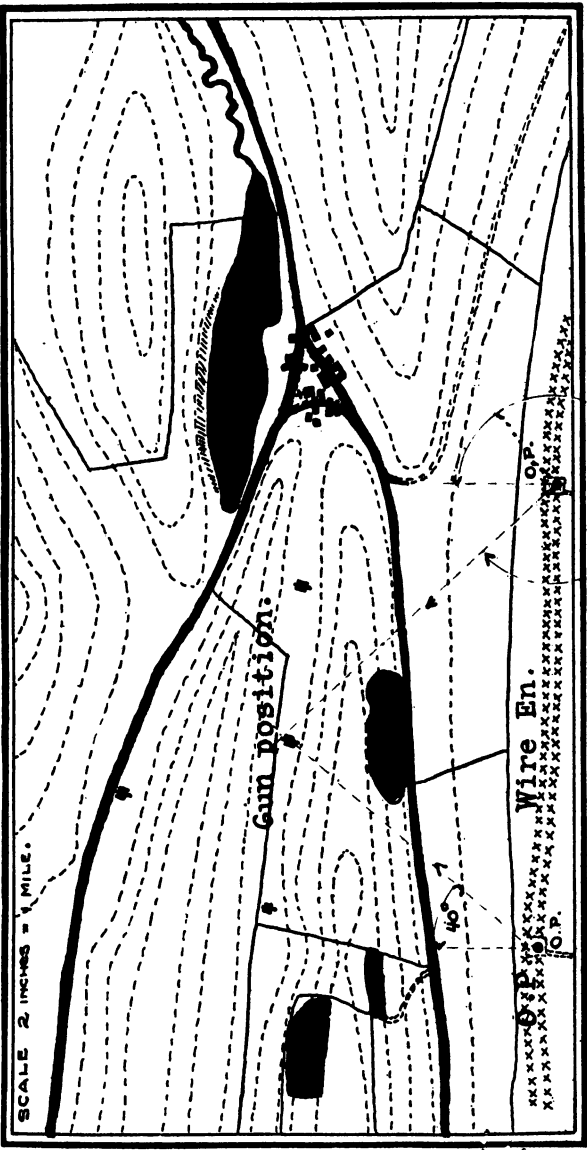

SCALE 2 INCHES = 1 MILE.

Gun position.

Wire En.

O.P.

O.P.

3175



a range of 2,100 yards, getting the trajectory D, and by means of a plunging fire making the bridge and turn in the road at the **village** a dangerous spot.

In instructing and working out indirect fire, profile paper comes in very handy, as it is already ruled both ways and any scale can be used just by numbering the different lines as shown in plate No. 25.

Jump. Owing to the shock of discharge a vibratory motion is set up in the barrel, and at the moment the bullet leaves the bore of the rifle the muzzle is usually deflected from its original axis. This means that the line of actual departure seldom coincides with the axis of the barrel before firing, and the difference between the two is known as the jump. This causes a slight over-throw in fixed rifles, and in the longer ranges should be given consideration.

Danger spaces decrease in extent as the range increases, the reduction being due to the steeper angle at which the bullet strikes the ground. The intelligence officer should take and work out by means of the trajectory tables given elsewhere in this text book a large diagram, showing the actual angles of descent at all ranges from 100 to 2,700 yards, and in explaining indirect fire the actual danger space can be measured off this diagram for any given height of object.

Ricochets. Bullets, which rebound after striking the ground or any other obstacle and continue their flight, are said to ricochet.

Firing up and down hill. When a fixed rifle is fired at a target placed on the same level as the rifle, the forces acting on the bullet cause it to travel in its greatest curve, and the greatest elevation for any given distance must, therefore, be given to the rifle. If a shot was fired straight up or down, no elevation is required. Consequently when shooting

up or down a slope less elevation is necessary than when the rifle and the object are on the same level. A careful working out of the trajectory on profile paper and observation of fire will soon enable the observer to set his rifle with negligible error.

Barometric pressure and temperature. All rifles are sighted at the factory under the following conditions:

- (a) Barometric pressure, 30 inches (sea level).
- (b) Thermometer, 60 degrees Fahrenheit.
- (c) Still air.
- (d) A horizontal line of sight.

When the barometer rises above 30 inches, more elevation will be necessary, owing to the greater resistance offered to the bullet by denser atmosphere. If the barometer falls below 30 inches, as in damp weather, or at a height above sea level, less elevation will be required than that marked on the sights for any given distance. In the same manner the bullet meets with less resistance in hot weather when the thermometer is high, and more in cold weather when it is low.

The following rule for corrections in barometric pressure is about correct.

For every inch the barometer rises or falls, add, or deduct, $1\frac{1}{2}$ yards per 100 yards of range.

Thus a reduction of 30 yards in 2,000-yard range would be required if the barometer stood at 29 inches. The barometer falls about 1 inch for every 1000 feet of altitude. At an altitude of 5,000 feet it would, in normal conditions of weather, stand at 25 inches, and for 2,000-yard range the elevation required would only be 1,850 yards.

Wind. One of the chief causes of trouble in the fixed rifle is the effect of wind on the course of the bullet. The direction and force of a wind can be found in a special article on wind observation in the

back of this text book. **A side wind** acts on the greater surface of the bullet and has, consequently, more influence on its flight than a wind blowing from the front or rear. **A wind from the front** retards the bullet and demands more elevation; one **from the rear** lessens the resistance of the air and consequently calls for less elevation.

The firer should study the effect of wind on the bullet's strike, as there are no definite rules to follow in this case, and by personal observation only will he become really efficient in making the allowance required.

In these short observations on setting and firing fixed rifles, it is impossible to deal with the subject in a manner which would completely cover the ground. In order to become fully efficient in the subject it is necessary to take a full musketry course, and carefully go into all the details pertaining to each different question. **This is in addition** to a special knowledge in map reading and a working knowledge of constructing sectional drawings on profile paper.

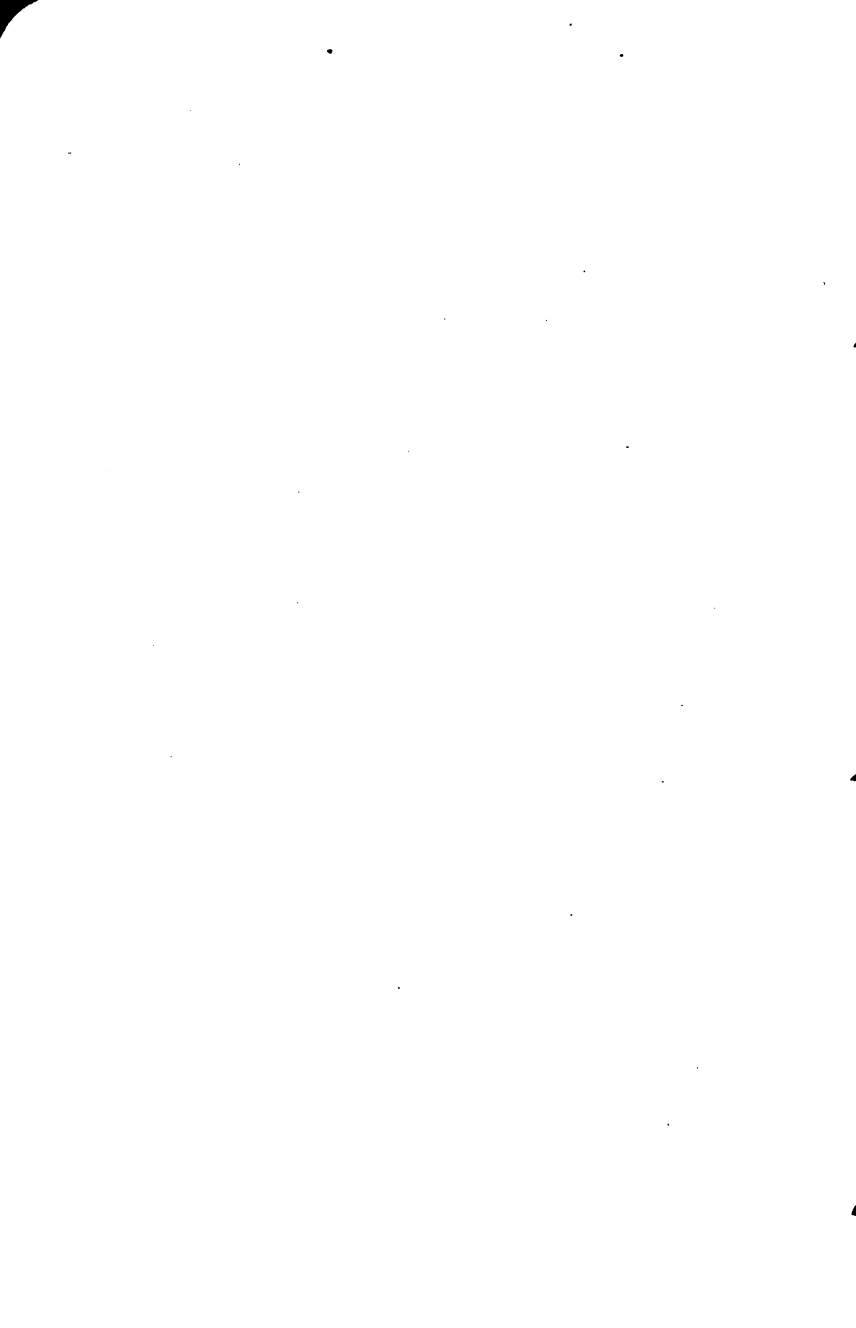

CHAPTER VII.

Aeroplanes—Aeroplane Maps

Aeroplane Photographs.

Aeroplane photographs have become of great importance during the last year, and are becoming more so every day. The allotment of personnel for photograph service was only one squadron per army a year ago. Now we have one photograph squadron per corps, the work having become so important.

They have to photograph the whole of the corps front to a distance of $1\frac{1}{2}$ miles behind the enemy's lines, which means that many more photographs are taken in one month's time than there were taken for the whole army a year ago.

The first prints of any photograph go to the army, corps, corps heavy artillery, division and brigade concerned. Only a limited number of copies for the above staffs are made, usually seven in all. Afterwards a wider distribution is made.

Special intelligence staffs, who make a specialty of reading, classifying and computing scales for these photographs, are rapidly increasing the knowledge to be secured from them, and it is only a question of a very short time when an aeroplane photo will give to one of the experts an almost full knowledge of the district which the photograph covers.

Method of Taking Photographs. To be of real value the photograph must be taken vertically downwards, usually from a height of 6,000 to 7,000 feet; even then there is some distortion towards the edges. A panorama or oblique photograph is very useful in several ways, such as giving a very clear idea of the country over which an attack is

to be made. It shows the state of the ground, whether soil is tilled or not, condition of buildings, roads, railways, etc. They are also useful in following out the course of railways, roads, rivers and the enemy's trenches. One good panorama photograph would take the place of a number of vertical photographs in this work; but for the purposes of any accurate information for trench maps or for estimating ranges by scales or triangulation, etc., oblique photographs are useless.

Consequently nearly all photographs are taken vertically downwards. The camera is let down through a hole in the floor of the aeroplane and rests on a spongy strip of rubber material on each side, so as to prevent vibration spoiling the photograph. The shutter is operated by the pilot or observer pressing a trigger attached to the camera handle on the camera. Plates have given much more satisfaction in this class of photography than the rolled films, as they are always perfectly flat and do not give distortion.

A photograph can be developed and printed in from five to seven minutes. The plates are 4 x 5 inches and cover a space about 800 yards by 1,000 yards when taken at the elevations above mentioned. A certain number of contact prints taken by our flying men are given to the French and Belgian staffs. The prints we use are enlarged to 6 x 8 inches. The drying of plates and prints is done very quickly by dipping them in metholated spirits and burning the spirit off.

Use of Aeroplane Photos.

1. **Maps.** All French maps are prepared from aeroplane photographs. The French maps in existence before the present war were of various kinds; sufficient to say that the main roads, railway lines and rivers were fairly accurate, but the minor



AN AEROPLANE PHOTOGRAPH

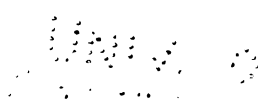

detail was very bad. The Belgian surveys were more accurate, but not accurate enough.

After various methods had been tried to make use of the aeroplane photograph for plotting accurate detail, we adopted the camera sueida. This apparatus is composed essentially of a prism and a universal stand on which to hold the photo. As the French and Belgian maps were accurate as regards main roads and principal points, it follows that if one can fit these main roads and points on a map from a photo, then one can plot in accurate detail from the photo.

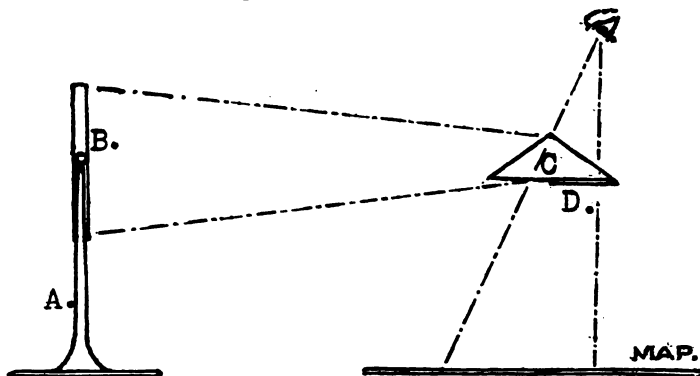

Camera Sueida and Universal Frame.

A is the frame which can be turned in any direction.

B is photograph attached to the frame.

C is prism with D- $\frac{1}{2}$ side silvered.

The map is below the prism and the eye above. By moving the prism or frame we can interpose the image of the photograph over the map and so fit on the main roads, etc., until the map is set.

Then the detail can be drawn in. An extra lense usually has to be used to avoid parallax. This



method is used to plot accurate details, such as hedges, houses, etc., and also to put in trenches and to plot gun positions. At the field survey company headquarters, second army, a printed trench map of the front is kept. All photographs are sent to them in the first instance and by the above means they are able to keep maps up to date as regards new work done.

When the changes get too numerous, new copies are printed at home with the up-to-date corrections. Accurate minor details, such as hedges, etc., are required for the use of artillery. The latest maps made by this method are accurate to about 25 yards. Owing to wet printing there is a little inaccuracy due to expansion of paper so as a rule center of photo is used only.

2. Intelligence.

Is the word used to mean the understanding and use of aeroplane photographs to give or to confirm information as to the enemy's intentions, state of his trenches, wire, position of his machine guns, trench mortars, dumps, batteries, etc.

First of all one must realize that photographs can only be used as a confirmation. One cannot depend for accurate information upon the photograph alone. You must have confirmation from direct observation, either on the ground by observers for the artillery, or scouts or patrols. Another good source is from the observers in captive balloons who are generally equipped with the best of glasses and secure a great deal of useful information.

Attack by Enemy.

Photos are useful to us for confirmation in conjunction with such information as obtained by action of the enemy, prisoners' statements, captured documents, etc. When the monthly photographs are taken of the corps front they are compared

with the previous ones. As an indication of an attack by the enemy look for the pushing out and joining of saps in "No Man's Land", more communication trenches under construction, new work on old communication trenches, new assembly trenches, new trench mortar emplacements and also new pits and emplacements of machine guns, new dumps formed and more materials brought up. Look for new batteries. Also look on the flank photographs to see how big an affair the attack is going to be, and if the preparation actively extends any distance to right or left of your position.

New railway sidings are very suspicious; they mean preparation to move men in large numbers, large rail guns, ammunition, wounded to the rear, etc. All of the above can be confirmed by the careful study of air photographs.

Attack by Us.

One of the first things you should note is the enemy's wire; in what state of destruction has the bombardment left it. This is rather difficult to do from an aeroplane photograph, nevertheless much information can be gotten from them. You can also get an excellent idea of the state of the enemy's trenches, his machine gun positions, reserve trenches, etc. He often has machine guns in shell holes behind his firing line which could hardly be discovered by aeroplane photographs. From the photograph you should be able to tell the attacking infantry what has been destroyed and what has not. They are also useful for giving information as to the position reached by the infantry. This is done by prearranged signals, such as when say half an hour has passed after the infantry have reached their objective. An aeroplane will fly over the line of objectives, and the infantry can, by displaying the prearranged signals, indicate to the aeroplane their position in the battle line, thus giving head-

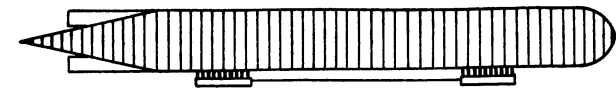

670-foot War Zeppelin.



British Scout.



British Parsival.



Schutte-Lans (rigid).

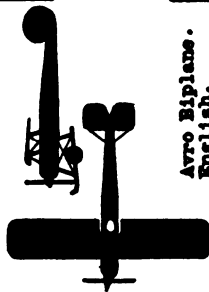

Avro Biplane.
English.



Curtiss Scout.
American.

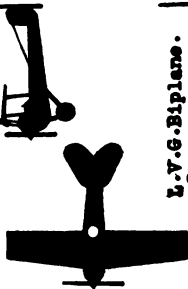

L.V.G. Biplane.
German.

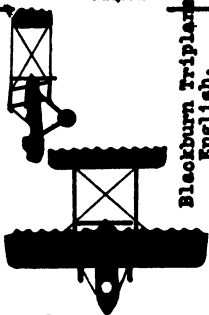

Blackburn Triplane
English.

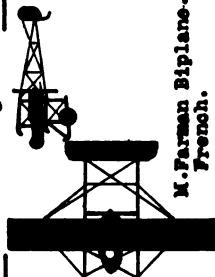

M. Farman Biplane.
French.

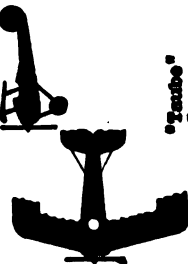

"Taube"
German.



Bristol Scout.
English.



Morane-Saulnier.
French.



Wright Scout.
American.



C. D. A. Sawyer

Sky Views.

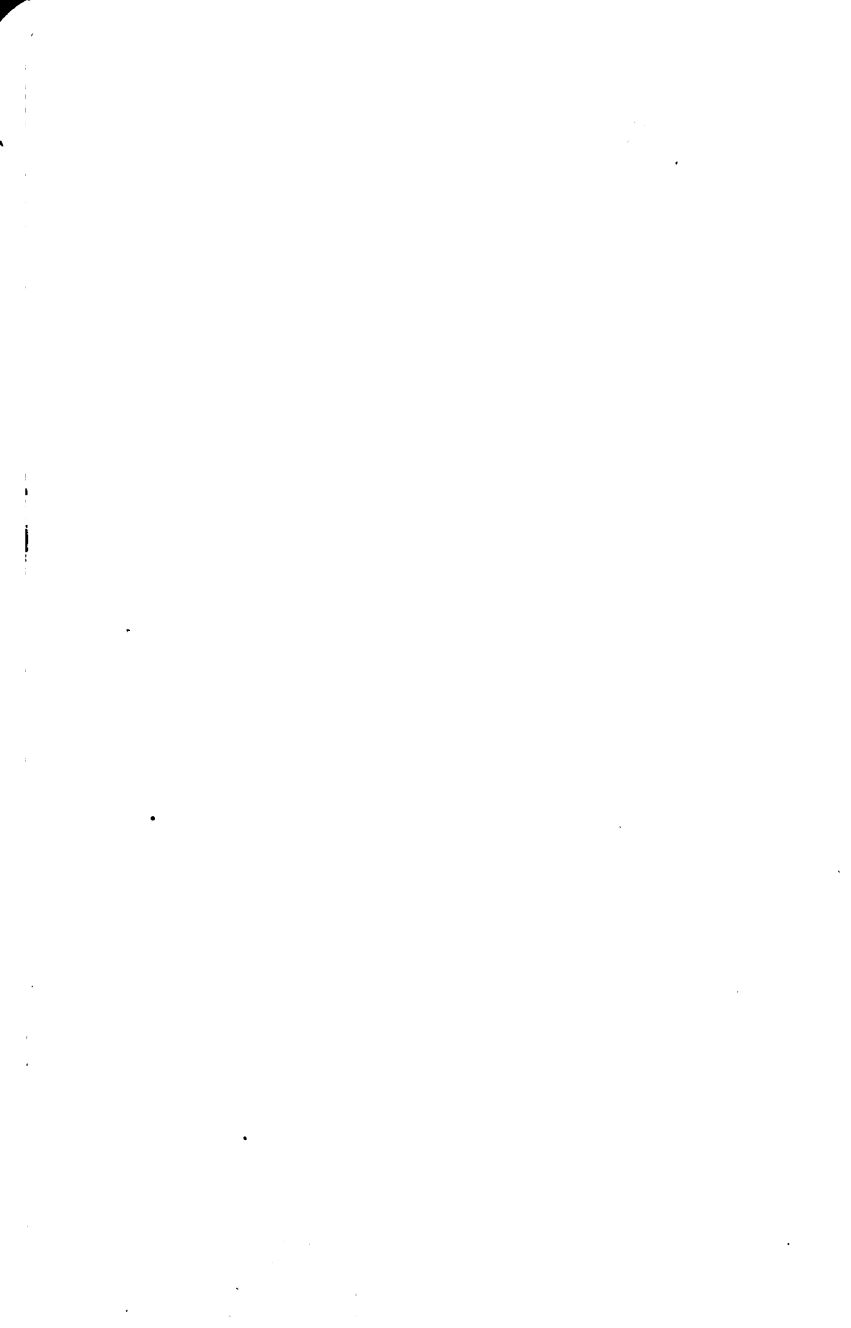

quarters in some 10 or 15 minutes later a photograph of the actual battle line, and how the troops are distributed. And should any part of the line be held up reinforcements can be rushed to the spot, or the flanking battalions ordered to give their assistance.

Trench Details.

Wire.

Wire is usually easily discernible, especially in snow pictures. It shows up in front of trenches usually in dark lines. In snow pictures it shows up in black lines. In woods it is rather hard to discover as a rule, but in fields it shows up fairly distinct. In good photographs it is often possible to see the posts, and in French photographs one has been able to distinguish knife posts. The enemy often has lines far behind his firing line which have been wired only and no trenches dug. Machine gun emplacements have been prepared, but he does not dig trenches until necessary and when labor is obtainable.

Listening and Sentry Posts.

The Germans lay great importance on these. They are usually in shell holes and one can distinguish the paths leading out to them or can see how they are joined up to the firing line by a trench. The best way to look at a photograph is to hold it so that you look into anything you know is a depression. Look at the photograph the opposite way to which the light is coming from. Trees give a good guide as to the light, as they cast a shadow, even on quite a dull day. Speaking of light and shadow, any mound of earth generally shows white and any depression black—or at least part of it is black.

The stereoscope is useful for showing detail in relief. A member of the French aviation corps

has invented a form of stereoscope for aeroplane photographs. It is now being introduced into all the armies. It is necessary to take two photographs of the same piece of ground about 400 yards apart in the air. The photographs are then put in the stereoscope and after focusing, etc., will show up in excellent relief.

Trenches.

The Germans usually have a first line system of trenches of three lines. Then an intermediate line several kilometers back of his reserves and then several more lines and partially prepared lines. He is also partial to switch trenches, which we will deal with later.

An ordinary dug-in trench usually shows with a heavy dark line in the center, with a wider white or yellow line on either side. The dark line is the trench proper, and the two light-colored sides are the earth piled out to form the parapet and parados. In any ordinarily fair photograph you can make out all the traverses and various turns in the line.

Very often a trench will appear shallow; that is, the dark center line will appear rather light in color. This is sometimes due to the light which may be shining down the trench. Trenches used a great deal can be recognized by their outstanding effect. Trenches in disuse are hard to see and distinguish easily. New work on the snow shows black and indistinct and with no snow shows very white as to the soil and dark as to the trench itself.

Switch Trenches.

The Germans are very partial to switch trenches and they should be noted in photographs so that the guns may give them their care in the case of an advance. A switch trench is really a communication trench well wired on the front. It has

Aeroplane Emblems



United States of America



Great Britain and Colonies

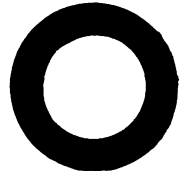

Navy
(Alternative)

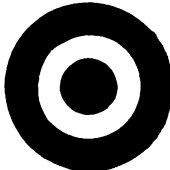

France Belgium Serbia and Roumania



Italy



Russia



Russia

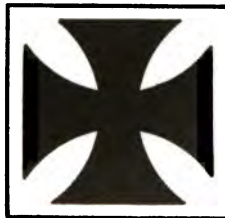

Germany
Austria Hungary
Bulgaria
Turkey



machine gun emplacements and a fire step. Their use is in the event of the front line breaking down in the defense; the troops can retire into the switch trenches and meet the advance with fire from the flanks. It is of the utmost importance to recognize these trenches in the aeroplane photographs, and be prepared to meet their defense.

The strutting of trenches can be recognized by small white lines across the dark line of the trench. The German usually does this strutting in mining areas. The intermediate line is usually strongly wired and provided with good dug-outs.

Machine Gun Emplacements.

These are extremely hard to discover from photographs alone. Photographs are only a guide in confirming their position. The essential thing is to look for some place where there will be a good opportunity for flanking fire along the wire. In some cases one can see the loophole; but this is an uncertain indication. Very often the Germans make their machine gun emplacements with the dug-out for the team, and an observation post for the observer. So that if you see a dug-out and an O. P. there is a fair certainty that there is a machine gun there. But always look for flanking fire. Look for it also in the switch trenches. It is seldom you find it behind the line in shell holes.

In the lines far back that are only wired, you can easily pick out his concrete machine gun emplacements, as you can see the concrete work and the paths leading up to them. These emplacements should be carefully marked for future attention after he has dug his trenches and occupied the line.

Trench Mortars.

Are also very hard to find, the light mortar especially, which may be actually in his firing line.

The medium and heavy ones are not quite so difficult as they are usually near a trench tramway to allow for the bringing up of the heavy ammunition.

They may be as much as 700 or 800 yards in rear of his front line owing to their range. Trench mortar emplacements can easily be mistaken for latrines and vice versa. As a rule trench mortars have a traverse leading up to them, while latrines have a straight trench leading in.

In some photos of the German lines, the trench mortar emplacements can be recognized by seeing two dark spots or openings. One of these is the entrance, where you go down some 10 or 12 feet, then along an underground passage or sap, to the gun emplacement proper, the other opening being the firing aperture, and very often you can even see the air inlet. But in most cases they are more often open emplacements, just shown by a dark patch.

Look for the trench tramways; they are nearly always close at hand.

Dug-Outs.

Recognized often by the white mound of earth over them. In the case of concrete the more or less regular roof made of concrete slabs shows up. They also very often have a trench tramway near them to carry up the concrete blocks. In many cases there are a large number of entrances to them from the trench.

If photographs are studied often they can be located whilst under construction. In the course of construction they appear as a hole only, which later becomes covered and in some cases camouflaged. Dug-outs under parapet and parados can be sometimes recognized by comparing breadth of parapet and parados with other portions of the trench.

Large dug-outs in the center or commanding portion of a sector often denote a headquarters. They

are sometimes near a trench tramway, and in some cases you can see buried cables leading into them, by the newly covered trenches. This would only be in the event of quite recent work.

Trench Tramways.

Usually recognized by their straight, narrow appearance, with easy curves. Sometimes they are hard to distinguish from paths, but the paths are not so definite. Trench tramways are very often run in a trench, and sometimes are completely camouflaged by the covering of the trench with chicken wire. This wire is covered by dry grass, painted mottled, or by other means bringing it to the color of the ground about, which completely stops all chance of a record of the trench in the photo. One can very often only spot a trench of this nature by the remains of the earth dumps along its borders, or the dumps at the end of waste earth.

The Germans have a very extensive system of trench tramways and he often runs them just behind the firing line.

Paths.

It is very important to study paths carefully; they give very important information. Note where they run through the enemy's wire. After daylight comes, a photograph taken as early as possible will as a rule show the tracks of the patrol parties in the night dew, where they went and the work they did, such as fixing broken wire; likewise the working parties that have been bringing up new supplies of grenades, food, gas cylinders generally lead direct to the dumps in the trenches where these articles are stored.

In many photos, the paths used by the officer commanding can be traced around the mined sectors, when visiting his posts at night. These same

parts very often give information as to how the firing line is divided into sectors. At the junction of two sectors the work on the line, i. e., dug-outs, etc., often decreases as compared to that well done in the sector.

Paths from the different dumps and refilling points to the line also indicate different sectors. Panoramic photos do very well on this class of photo.

Paths are very important in the vicinity of batteries and quite often give their positions away.

Buried Cables.

These can only be seen, as a rule, for a few weeks after being covered in. They are rather indistinct white lines usually pretty straight. They often lead to suspicions as regards battery positions and headquarters. They never cross a trench but are carried under it by U-pipes. Air-lines and posts can often be distinguished.

Dumps.

Usually at the head of trench tramways and as a rule have trench tramways or light railway leading to them. Behind the line the larger dumps are on the normal gauge railways. Maps are needed to make sure of dumps, i. e., to see if the houses have been increased. But generally one can see piles of various material stacked around. Enemy ammunition stores are usually very carefully stacked in separate sheds and often covered up with a good covering of earth. There are usually anti-aircraft guns in the vicinity, and a good deal of movement about the place.

Battery Positions.

It is impossible to pick out battery positions from photos alone. The approximate vicinity is worked out by flash spotters working in three observation posts, and by sound ranging sections. Photos are then taken in the vicinity and the bat-

tery position is then looked for. The German is very cunning in concealing their guns. They put them in an open emplacement and as soon as possible covers them up and camouflages them. It is therefore very necessary to study carefully all photos to see if one can spot positions in course of construction. Paths and buried cables are two methods of spotting them. Wagon tracks from bringing material for the emplacement are often seen, but they generally lay wide strips of heavy canvas on the ground for the last 100 or 150 yards, which the men and wagons travel on, thus losing the trail. This canvas being taken up before daylight and laid again after dark. The scotch of the guns very often give their positions. This is especially noticeable in the snow, but can also be detected without snow on the ground.

The Germans often make camouflage blast marks, but these can generally be recognized by their regularity. In one case a battery was spotted and shelled by noticing that the hedge behind which it was located was thicker than other hedges and had faint tracks leading up to it. In some places they have gun emplacements in actual trench lines behind the firing line.

The old type of German emplacement was a round hole in the ground; now they have several types.

Anti-aircraft guns can be easily recognized by their appearance, the round cement platform with a black spot in the center; this applies also to a stationary gun. A square light colored spot with a black spot in the center indicates a motor lorry or truck gun.

For heavy railway guns look for sidings ending nowhere. They are usually spotted so they can fire in different directions.

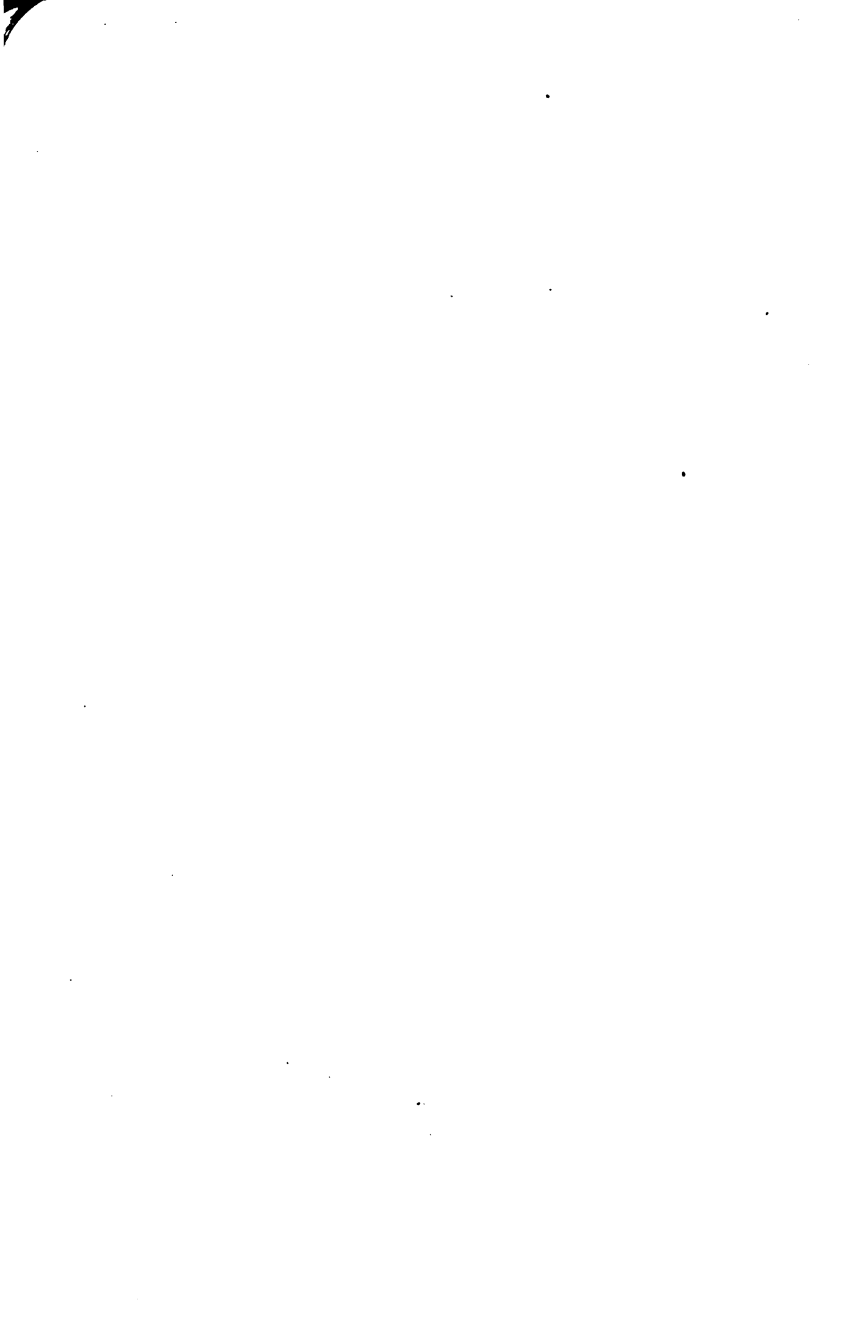

CHAPTER VIII.

General Information for Intelligence Section

Sanitation and Care of the Feet.

In view of the length of time that the same line of trenches frequently have to be held and occupied, especial precaution has to be taken to keep trenches in a clean and sanitary condition. Iron buckets or tins must be arranged for in the latrines, if possible. A good supply of chlorate of lime should be kept in each trench to be used daily. Places for burying all empty tin cans and rubbish should be carefully picked out, as far from the trench as it is practicable; these places should be marked and used for that purpose only.

The disease known as "Trench feet" is caused by prolonged standing in cold water or mud and by the continued wearing of wet socks, boots and puttees. It is brought on much more rapidly when the blood circulation is interfered with by the use of tight boots, tight puttees or the wearing of anything calculated to cause constriction of the lower limbs.

It can be prevented by:—

1. **Improvements to trenches** leading to dry standing and warmth.
2. **Battalion arrangements** ensuring that the men's feet and legs are well rubbed with whale oil or anti-frostbite grease before entering the trenches, and that, so far as possible, men reach the trenches with dry boots, socks, trousers and puttees.
3. **Long gum boots** should be issued in the trenches in bad weather, and put on the feet while the men's feet are still dry. Gum

boots should not be kept on longer than necessary, as owing to the lack of ventilation, men's feet sweat freely in them and the boots become wet.

4. **By taking every opportunity** while in the trenches to have boots and socks taken off from time to time, the feet dried, well rubbed and dry socks (of which each man should carry a pair) to put on.
5. **By arrangements to give the men some exercise daily** so as to maintain the blood circulation.
6. **By the provision of warm food** in the trenches when possible, and by providing warmth, shelter, hot food and facilities for washing the feet and drying wet clothes for men leaving the trenches.
7. **It is important** that a quantity of extra boots be kept on hand in the battalion so that the men whose boots need repair can be given another pair while their own are in the hands of the shoemaker.

6. Defensive Measures Against Gas Attacks.

Every officer is responsible that the men under his command are properly instructed in defensive measures against gas attacks, that all appliances are at all times in perfect order and that standing orders on the subject are thoroughly understood.

During a gas attack it is important that all measures taken should be carried out with the utmost calm in order to avoid confusion and waste of energy.

The officer and men of every battalion intelligence section should thoroughly understand and know all the dangers and means of combatting an enemy gas attack. Their observation post work will include wind observation and the furnishing of reports on the same at stated times.



A TYPE OF GAS MASK

The scouts and snipers must be given daily instruction work, in the adjustment and wearing of their gas appliances, until they can perform their special work with gas masks and respirators on without their interfering with their work.

General Considerations

In the absence of suitable means of protection, the poison gases used in war are extremely deadly, and the breathing of only very small quantities of same may cause death or serious injury. This being the case, it is essential that not the slightest time should be lost in putting on the box respirator or helmet on the gas alarm being given.

It cannot be too **strongly insisted on** that the measures which have been elaborated to meet hostile gas attacks **afford perfect protection**, and if they are carried out properly no one will suffer from gas poisoning.

The whole basis of protecting troops against gas lies (a) in keeping the appliances in perfect working order; (b) in learning to adjust them rapidly under all conditions; and (c) in ensuring that every man is given immediate warning. These results can only be attained:

1. **By frequent and thorough inspection of all protective appliances.**
2. **By thorough instruction and training in their use.**
3. **By every man understanding and complying with all standing orders on the subject of defense against gas.**

If these are effectually carried out, there is nothing to fear from hostile gas attacks. Officers must impress this upon their men, as an important object of all anti-gas instruction should be to inspire complete confidence in the efficacy of the methods which are adopted.

Anti-Gas Equipment Carried.

Each man is provided with a small box respirator, a P. H. helmet and a pair of goggles. He must be made to realize that these appliances are **personal equipment; that they are of importance second only to his weapons, and that his life may depend on looking after them and keeping them in good order.**

The small box respirator is the most important protective apparatus. It is always to be used first in case of a gas attack, unless special orders are issued to the contrary. It will protect against all poisonous gases with the exception of mine and explosion gases, and will not become exhausted for hours, even in concentrations of gas for testing purposes which is greater than encountered in field.

The P. H. helmet is an emergency or reserve defense. It is only to be used if the owner should not have a box respirator or if the latter should be found, for any reason, to be defective. The helmet protects against all poisonous gases used by the enemy, but it does not give complete protection against any heavy bombardment by lachrymatory shells. It is not possible to put the P. H. helmet on as quickly as the small box respirator.

The rubber sponge goggles are intended for use in areas which have been subjected to a bombardment with lachrymatory shells, and in which the concentration of the lachrymator is so reduced that the air can be breathed without discomfort, though effect on the eyes remains. It must be remembered that after such a bombardment the tear producing effect may persist, even in the open, for several hours, and in trenches, dug-outs, cellars, etc., it may last for even a day.

When and Where Carried.

- (a) **All three appliances** should be carried within three miles of the front line.

- (b) When the wind is safe, working parties during work and at the direction of the officer in command may take off their box respirators, provided the latter are placed conveniently at hand for use in case of a sudden gas shell attack or change of wind. The P. H. helmet will always be carried.
- (c) **At distances greater than three miles** the P. H. helmet and goggles need only be carried, the box respirators being kept with the equipment under arrangements by the officer commanding the unit.

Protection of Weapons and Equipment.

Arms and ammunition and the metal parts of special equipment (i. e., telephone instruments, range finders, compasses, periscopes, vigilant glasses, clinometers and watches) must be carefully protected against gas by greasing them or keeping them completely covered. Otherwise, particularly in damp weather, they will rust or corrode so badly as to refuse to act. A mineral oil must be used for this purpose.

Rifles and revolvers must be kept carefully cleaned and well oiled. The effect of corrosion of ammunition is of even more importance than the direct effects of gas upon rifles and revolvers.

Ammunition boxes must be kept closed. The wooden bandolier boxes are fairly gas tight, but the metal inner box should be made gas tight by inserting strips of flannelette in the joint between the lid of tin box and the outer wooden case.

A recess should be made, high up in the parapet if possible, and used for the storing of snipers' rifles, ammunition and instruments when not in use. A blanket curtain, fitting the opening well, and moistened with water or vermoresl sprayer solution will greatly assist in keeping the gas out of the storage hole.

Unboxed hand and rifle grenades should be kept covered as far as possible. All safety pins and working parts, especially those made of brass, should be kept oiled to prevent their setting from corrosion by the gas.

Wind Observation.

The Army Meteorological Service reports to headquarters of formations whenever the wind passes into a dangerous quarter, showing the direction and strength of the wind. As a result of these reports, "gas alert" is ordered by corps or divisional headquarters. These general reports, however, refer to large tracts of country, and it is possible that on isolated lengths of front, conditions of terrain or the alignment of the trenches may permit of local air currents which are favorable to the enemy. It is essential, therefore, that the troops themselves should be on the look-out for the possibility of a gas attack. For this reason intelligence officers and non-commissioned officers are responsible to the officer commanding unit and company commanders that wind observations are made on their own frontage every three hours at least, if the wind is in, or approaching, a dangerous quarter, and the reports forwarded through the usual channels to brigade headquarters.

Gas Alert Period.

Gas alert will be ordered when the wind is in the dangerous quarter, no matter what the strength of the wind.

The order "gas alert" will be sent out to all units by corps headquarters (or, if authority has been delegated, by divisional headquarters), but brigade headquarters or battalion commanders are empowered to order a "gas alert" as a result of wind observations forwarded by the intelligence or company officers. Such action will be reported immediately to the next higher formation.

"Gas alert" notices should be posted at the entrance to each main communication trench and at other suitable points within divisional areas.

Protection of Carrier Pigeons.

When the gas alarm is sounded, all baskets containing pigeons should be placed in the **special anti-gas bags** provided for this purpose or placed in gas-proof shelters. If for any reason the birds cannot be protected from the gas, they should be **set free at once**. Anti-gas bags should always be kept near baskets containing birds and should be regularly inspected.

Pigeons can be utilized during a gas attack. Experience has proven that they will fly through any gas cloud, but it is imperative that the bird should not be exposed to the gas any longer than possible.

The message and carrier should be prepared and if possible fastened to the pigeon's leg before the bird is exposed to the gas. Twenty seconds should suffice to fix a carrier and free a bird.

Specimen Standing Orders.

Action During Gas Alert and Hostile Gas Attacks. Ordering of Gas Alert.

Gas alert will be ordered when the wind is in the dangerous quarter, no matter what the strength of the wind.

The order "Gas Alert" will be sent out to all units by corps headquarters, except in such cases as a local attack, when orders will come from brigade or battalion headquarters.

Inspection of Box Respirators and Helmets.

All box respirators and helmets will be carefully inspected daily, and at once after a gas attack.

Alert Position for Box Respirators.

All ranks within one mile of the front line will carry their box respirators in the alert position. Nothing slung across the chest must interfere with the immediate use of the respirator.

Special Orders for Men Using P. H. Helmets.

The helmet will be carried in the alert position, i. e., pinned through the wallet on to the shirt and rolled in such a manner as to protect the valve and leave the helmet suspended ready to put on the moment the jacket is opened.

The two upper buttons of both jacket and great coat will be left undone. Men are forbidden to wear mackintosh sheets around their shoulders, or mufflers around their necks.

In no circumstances will anything (rifle, field glasses, etc.) be slung across the chest in such a manner as to interfere with the rapid adjustment of the helmet.

Jackets will not be taken off within one mile of the front line.

Officers and non-commissioned officers in charge of any unit or party must see that the orders are strictly carried out, both for troops in the front line trenches and for detached bodies of troops (working and carrying parties, etc.).

Sentries, Etc.

All working parties will have a sentry posted to give instant warning of a gas attack.

A sentry will be posted at each warning horn or other alarm device and fully instructed in its use.

A sentry will be posted to every large dug-out and to each group of small dug-outs.

A sentry will be posted to each headquarters, signal office group of snipers' posts and independent body of men.

Arrangements will be made by the officer in charge of the trench for warning the artillery observation post if there is one in the trench.

Commanders of units in billets within 8 miles of the front line trenches will organize a system of giving the alarm and rousing all men in cellars and houses.

At night sentries must have at least two men within reach of them so that the alarm can be spread rapidly.

Sleeping.

When a gas attack is probable, men in front line trenches will sleep on the fire step instead of in the dug-outs.

Men sleeping in rearward lines or in works where they are allowed to take off their equipment, will sleep with their respirators on the person.

Company Gas Non-Commissioned Officers.

Company gas non-commissioned officers will report to their company headquarters in readiness to assist the company commander should a gas attack occur.

Ammonia Capsules.

Medical officers in charge of units must see that a proper proportion of the ammonia capsules are with stretcher bearers in the front line, in readiness for their immediate use after a gas attack.

Gas Alarm.

In the event of an enemy gas attack the alarm will at once be given by all means available—by telephones, alarm horns, gongs and if necessary by orderly. Sentries will warn all ranks in trenches, dug-outs, observation and sniper posts and mine shafts.

All ranks will at once put on their box respirators or helmets.

Troops in the front line trenches and elsewhere where the tactical situation requires it, will stand to arms. All ranks in the front line are forbidden to remain in, or go into, dug-outs or move to a flank or to the rear.

If troops in support or reserve lines of trenches remain in, or go into unprotected dug-outs, they must continue to wear their anti-gas appliances.

Unnecessary Movement to Cease.

There must be as little movement and talking as possible.

On the alarm being given, all bodies of troops or transport on the move will halt and all working parties cease work until the gas cloud has passed.

If a relief is going in, units should stand steady as far as possible until the gas cloud has passed.

Supports and parties bringing up ammunition and grenades will only be moved up if the tactical situation demands.

Protected Shelters.

The blanket doorways of protected dug-outs, cellars, etc., will be let down and carefully fixed in position.

Action During an Enemy Gas Attack.

Should the gas cloud be unaccompanied by an infantry attack, the signal for gas will be sent and the S. O. S. signal will not be made unless an infantry attack develops.

Tactical Measures.

The troops in the front trenches will open a slow rate of rifle fire against the enemy trenches; occasional short bursts should be fired from machine guns to ascertain that these are in working order.

All available howitzers should be turned on the enemy's trenches, from which the gas is being emitted, or in which the enemy infantry may be concentrating for the assault.

Should any infantry attack develop, the normal procedure of S. O. S. will be carried out.

Troops in the front line must be prepared to bring a crossfire to bear on the enemy attempting to advance against a gassed portion of the line.

Movement.

All movement must be reduced to a minimum. There should be as little moving about and talking as possible in the trenches. Men must be made to realize that, with the gas now used by the enemy, the observance of this rule may be essential for their safety.

Action After an Enemy Gas Attack.

Men in charge of anti-gas fans will use them as soon as the gas cloud has passed, so as to admit of respirators being removed.

Box respirators and helmets will not be removed after a gas attack until permission has been given by the different company commanders, who will, when possible, ascertain from officers and non-commissioned officers who have been trained at a gas school that it is safe to do so.

Preparation for a Subsequent Attack.

So as to be ready for a subsequent gas cloud, all ranks will replace their box respirators or helmets in the "alert" position.

A sharp lookout must be maintained for a repetition of the gas attack as long as the wind continues in the dangerous quarter.

Clearing of Shelters.

Dug-outs, cellars, etc., must not be entered before they have been thoroughly ventilated, except by men wearing box respirators or helmets. Thorough ventilation, by means of fires or anti-gas fans, is the only sure way of clearing a shelter.

Movement After Gas Has Passed.

No man suffering from the effects of gas is to be allowed to walk to the dressing station.

The clearing of trenches and dug-outs must **not** be carried out by men who have been affected by the gas.

After a gas attack, troops in the front trenches are to be allowed off all fatiguing and carrying work for 24 hours by sending up working parties from companies in the rear.

Horses which have been exposed to the gas should not be worked for 24 hours if it can be avoided.

Cleaning of Arms.

Rifles and others arms must be cleaned after a gas attack. Oil cleaning will prevent corrosion for 12 hours, but the first opportunity must be taken to clean all parts in boiling water containing a little soda.

Action During a Gas shell bombardment.

Box respirators or helmets will be worn in the area shelled.

Arrangements must be made for giving a **local alarm** in the event of a sudden and intense bombardment with gas shells.

All dug-outs and shelters in the vicinity will be visited and any sleeping men aroused.

Making Wind Observations and Furnishing Reports

Wind reports are to be made and handed to the company commanders every three hours or oftener, if the wind is in or approaching a dangerous quarter. In order to make these reports the following points must be attended to:—

Wind Vane

A simple wind vane must be set up. The vane must have as little friction as possible so that a wind of under 2 miles per hour will turn it. A little post at the top of the vane should carry a strip of light linen $\frac{3}{4}$ inch by 5 inches, by the movements of which the strength of the wind can be judged.

The vane must be set up sufficiently high to get a true observation (e. g. 18 inches above the top of the dug-out, etc.). Correct orientation should be obtained by getting north by the north star and south by the sun at midday (Greenwich time).

Direction of Wind

Before reading the direction of the wind from the vanes the observer should gauge the approximate direction by noting the course taken by smoke, etc. Direction of wind must be stated in points of the compass. The points of the compass to be used are shown in Fig. 8.

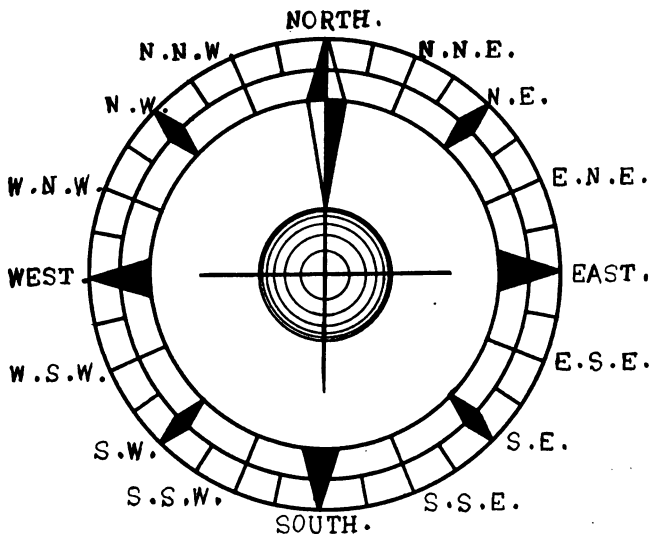

Strength of the Wind

Beaufort's No.	Speed in M. P. Hour	Observations of Natural Objects	Behavior of the Flag at Top of Vane
0	0	Smoke straight up.	.
1	2	Smoke slants.	No movement.
2	5	Felt on face.	No movement.
3	10	Paper, etc., moved.	Slight.
4	15	Bushes sway	$\frac{3}{4}$ up.
5	20	Tree tops sway.	Up and falling often.
6	30	Wavelets on water.	Up, falling slightly.
		Trees sway and whistle.	Up and flapping.

Types of Report

The points north, south, east and west must be written in full. Other points are denoted by the usual letters.

The following example shows the type of report which should be made.

Wind Report.

Trench No. 131.		Date 3/10/17.
Time	Direction	Speed
6 P. M.	N. N. W.	14 m. p. h.

The following simple calculation determines the number of seconds which it will take for a gas cloud to move from the enemy's lines to the observer: Double trench distance (in yards) and divide by speed of wind (in m. p. h.).

$$\text{Example } \frac{100 \times 2}{10} = 20 \text{ seconds.}$$

Aeroplane Emblems.

In place of a flag, which would be unsuitable, the aeroplanes of the belligerent powers bear distinctive markings, based on the colors of the flag of the country they represent. The early British naval seaplanes used to employ the design of the Union Jack, but this was subsequently replaced by a red circle, or more recently by a red center, surrounded first by a white ring (or the natural color of the fabric), and then by a blue ring, which is the standard for the British army.

The positions of these markings are near the wing tips on the upper surface of the upper plane, and in similar positions on the underside of the lower plane. One mark is also placed on each side of the body, midway between the aviator's seat and the tail of the machine. The ring markings are

not, however, employed on the rudders. In this latter position it is usual to employ striped markings; e. g., **Great Britain** uses vertical red, white and blue stripes; **France** has blue, white and red vertical stripes on her aeroplane rudders, with circles of the reverse coloring to the British in the other positions. **The Belgian, Roumanian and Serbian colors** are similar to the French, though formerly the Belgians employed their national colors of black, yellow and red, the black being at the center of the circles.

The center of a circle, or the forward part of the marking on a rudder, is always similar to that next to the flagstaff as in the case of a flag; that is, the old established customs of flag usage are followed.

The Russian marks correspond to their flag, i. e., lateral stripes of white, blue and red, white being at the top or leading edge of a plane. On some of the later machines the circle system of marking has been adopted, hence the machines of all the allies are alike in that they all use circles.

The Italian circle mark has a red center, surrounded by a white ring and green outer circle.

The German, Austrian and Turkish distinctive mark is the well-known German cross (black) on a white ground. The earlier Turkish machines bore a white star and crescent on a red ground, In addition to the German cross, the Austrian machines often bear the national white and red stripes painted on the extremities of the wings. As well as the national emblems, the machines usually carry a number and class mark to indicate the service upon which they are engaged.

Experiments are being made to obtain paint colors that make an aeroplane on the ground invisible as possible from an aeroplane overhead. Similarly, it would be advisable to use paint for the under surfaces, thus reducing the visibility to the

enemy anti-aircraft guns, or at least increasing the difficulty of range-finding.

Extracts From German Documents Dealing With the "Battle of the Somme".

1. German Opinion of British Troops.

Previous to the attack the enemy's infantry patrols showed increased activity. The foremost trenches were probably lightly held during the intense artillery fire. The troops for the assault were apparently assembled in the trenches in the rear.

The attack on the first of July was well prepared, and the infantry was splendidly equipped with all kinds of weapons for the close combat. It was provided with a large number of Lewis guns, which were brought into action very quickly and skilfully in newly captured positions. It is very desirable that our infantry should be equipped with a large number of light machine guns of this description in order to increase the intensity of its fire.

The individual English soldier is well trained and shows personal bravery. Some of the Officers, however, are not sufficiently thoroughly trained. They are lacking in ability to exploit a success and to follow it up quickly.

The English infantry has undoubtedly learned much during recent months. It shows great dash in the attacks, a factor to which immense confidence in its overwhelming artillery probably greatly contributes. The Englishman also has his physique and training in his favor. Commanders, however, in difficult situations showed that they were not yet equal to their tasks. The men lost their heads and surrendered if they thought they were cut off.

Telephone connections were established very rapidly.

The enemy's trench mortars were skilfully served and produced effective results.

The enemy's artillery registered skilfully and inconspicuously. The guns proved accurate; the effect of the shells was good, but the percentage of blinds was high.

2. Description of German Position.

The first line position will be held if the enemy attacks. It consists of the first, second and third trenches, and should have, if possible, two rows of wire in front of each. There should be at least two communication trenches in each company sector from the third to the first trench, but the points at which they enter and leave the second trench should not be opposite one another. The number of dug-outs should be increased until there are sufficient to accommodate the infantry garrison necessary for the repulse of a prepared attack.

The intermediate and second line positions consist of at least two trenches, each provided with two rows of wire on pickets, and the same number of communication trenches as in the first line position. Each of the present regimental sectors must be provided with sufficient accommodation for at least one battalion.

Trenches.—Narrow trenches with steep sides again proved very disadvantageous and caused considerable more casualties (men being buried) than shallower trenches with a wide sole. One regiment is of the opinion that the garrison is better protected if the men lie down or crouch at the bottom of the trench without further cover, than if the so-called "rabbit holes" are used.

A cover trench roughly parallel to the front fire trench is not sound. Such trenches are destroyed by the enemy's fire at the same time as the actual fire trenches. To obviate this, trenches cited in accordance with the ground, and consequently with a certain irregularity of trace, are recommended.

Obstacles.—There should be two or three rows of wire, each from three to six yards deep, with

an interval of from six to eleven yards between each, this interval being provided with trip wires. The outer edge of the furthest wire should be about 55 yards from the trench. It should not always run parallel with the trench, but should follow the lay of the ground.

Dug-outs.—The thickness of earth overhead should be from 23 to 26 feet, and more in the case of command posts and the dug-outs for the medical services, telephones and kitchens. The dug-outs for the men should be sufficient for 16 men, with two entrances separated by a traverse. Several dug-outs should be connected up to form corridor dug-outs with accommodation for a platoon. The dug-out recesses should be on the same side as the entrances, not facing them. Entrances should be 4 feet by $5\frac{1}{4}$ feet, and should be well stayed and braced. Inclined galleries offer more resistance than frames built in on steps one below the other.

Machine guns.—It is advisable to employ the bulk of the machine guns not in, but behind, the first trench. When fixing their sitting, the possibility of delivering both frontal and flanking fire must not be forgotten. Used as an emergency garrison for the intermediate or second line position, they may prevent a break through if the enemy succeeds in overrunning the first line position.

Machine guns must, as a rule, be kept in the dug-outs of their crews until the enemy assaults, and must then be placed rapidly in position at suitable points on the parapet.

Machine gun units are particularly suitable for employment as a commander's reserve.

Retired positions.—The preparation of villages and other strong points afforded by the ground behind the front line, for subsequent defense, cannot be begun too soon.

The first necessities for retired positions and the extremely important diagonal switch lines, are **entanglements, dug-outs and communication trenches.**

Absender. { Dienstgrad
 Name

(Nachstehende Spalten genau nach der vom Truppenteil
 gegebenen Anweisung ausfüllen.)

.....	Regt. Nr.	} Sonstige Formationen. (Kolonnen, Flieger, Funker u/w.)
.....		
.....	{ Bataillon Abteilung	
.....	{ Kompagnie Batterie Escadron	

Feldpostnummer darf bei Stäben von Armeekorps, Divisionen und Brigaden und bei Formationen, die einem Regimentsverband angehören, nicht angegeben werden. } **Deutsche Feldpost**
 Nr.

Wohnung
 (Str. u. Hausnummer)

in

Nr.

Feldpostkarte

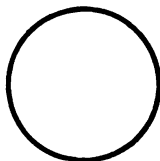

Aufgabestempel

The number of these positions should be increased by continued work, and by making the fullest possible use of all available forces.

3. Distribution of the German Infantry.

Method of Holding the Position.—One of the most important lessons drawn from the battle of the Somme is that, under heavy, methodical fire, the front line should be only thinly held, but by reliable men and a few machine guns, even when there is always a possibility of a hostile attack. When this was not done, the casualties were so great before the enemy's attack was launched that the possibility of the front line repulsing the attack by its own unaided efforts was very doubtful. The danger of the front line being rushed when so lightly held must be overcome by placing supports (infantry and machine guns) distributed in groups according to the ground, as close as possible behind the foremost fighting line. Their task is to rush forward to reinforce the front line at the moment the enemy attacks without waiting for orders.

The essential conditions for success are, therefore, that the various formations should be organized in depth but that their units should be employed side by side.

The garrison of the first trench of the first line position should be strong enough to repulse the enemy's attack, assuming that the men reach the parapet in time, but no stronger. It is, as a rule, sufficient to have one man to every two to three yards as an emergency garrison in the first trench.

The second trench of the first line position is garrisoned by the supports, one portion of which is specially detailed to defend the entrances to the communication trenches, while the other portion consists of strong, specially-formed bombing par-

ties, which are held in readiness to rush forward at once to the support of the foremost trench.

Reserves.—The company commander must, under no circumstances, neglect to provide himself with a reserve consisting of a few groups and, if possible, of machine guns as well. The sub-sector commanders must also have at all times sufficient troops at their disposal to be able at once to drive the enemy out, by means of a counter attack, should he succeed in penetrating into the position.

The fighting strength of both the front trenches would soon be exhausted if the sector reserves were not put in. These must therefore be brought close up in good time, either into the third trench or into the special reserve trenches. In case of an attack they should be moved forward into the second (or third) trench to replace the reinforcements which have already gone forward (the supports) and continue the task allotted to the latter.

In critical situations it is not sound to quarter reserves in villages immediately behind the front. It has nearly always proved impossible to assemble the troops quickly when they were scattered in numerous cellars, etc., in a village which was being heavily shelled. In such cases the reserves should be in the trenches.

In the fifth division, a fourth platoon was formed in the infantry companies. At first, these reinforcements for replacing casualties were kept back with the first line transport (field kitchens). They were sent forward only when the losses of the other three platoons made reinforcements necessary. When they went forward, the fourth platoons took with them all that had been found necessary in the particular fighting (hand grenades, entrenching tools, rations, etc.). This arrangement proved very successful.

Feldpostbrief

An

.....

.....

in

.....

Wohnung

(Straße und Hausnummer)

GERMAN FOLDING LETTER CARD (Front)

Abfender: { Dienstgrad
 { Name

(Nachstehende Spalten genau nach der vom Truppenteil
 gegebenen Anweisung ausfüllen.)

..... Rgt. Nr. { Bataillon { Abteilung { Kompagnie { Batterie { Eskadron	Sonstige Formationen: (Kolonnen, Flieger, Junker usw.)
---	---

Feldpostnummer darf bei Stäben von Armeekorps, Divisionen und Brigaden und bei Formationen, die einem Regimentsverband angehören, nicht angegeben werden. } Deutsche Feldpost
 Nr.

4. German Tactics.

Approach March.—Before bringing up troops into the zone of the enemy's artillery fire, the commander must obtain a clear idea, by means of clever scouts and by his own observation, how the enemy's fire is distributed over the ground to be crossed. When selecting the route, areas which are hardly or not under fire will be taken into consideration rather than the nature of the ground and the cultivation. Depressions and sunken roads which are invisible to the enemy are, as a rule, under such heavy barrage fire that it is not advisable to make use of them. Villages which lie in the enemy's zone of fire are to be avoided on principle.

Action When Heavily Shelled.—It has been found to be a good plan during the continuous heavy bombardment of incomplete front line positions for the garrison to advance 100 to 200 meters and to lie down in the open without cover.

Over ground which cannot be observed, and at night, the unaimed but horizontal **barrage fire of infantry and machine guns**, during and immediately after critical periods, affords rest and protection to troops who are probably shaken for the moment, and not only scares the enemy but inflicts losses on him.

The excellent results obtained from selected **snipers** posted at good viewpoints in trees, etc., are particularly emphasized by one regiment.

The detailing of **assaulting parties** in an attack has proved very useful. Their chief advantage lay in the freshness of the specially selected personnel who had not been engaged in previous fighting. The careful training beforehand of the assaulting parties resulted in these troops proving themselves quite equal to all tasks which fell to their lot in village or wood fighting. They felt that they

were a body of elite troops, which indeed they proved themselves to be.

When attacking in a wood, it is preferable, instead of the usual skirmish lines following one after the other, to employ small assaulting columns following a single line of assault.

Relief of Infantry and Engineers.—When troops are relieved, it is of the utmost importance that the outgoing troops are careful in handing over. Whenever the tactical conditions permit, this should take place on the spot, the various commanders meeting together for the purpose. At any rate, it is absolutely essential that the incoming troops should be thoroughly informed as to the tactical situation, by means of personal conferences between the commanders, with the assistance of maps and sketches which will be taken over by the former. A perfectly clear picture must be given of the state of the positions, etc., particularly of their weak points, and also of any work which it had been intended to carry out, the degree of importance attached to it being specified.

If it is impossible to give the incoming troops an idea of the ground beforehand, then detachments of the outgoing troops must be left behind in the trenches. It is very important that the junction points with other troops should be absolutely clearly indicated, as these are so easily forgotten when reliefs are carried out under heavy fire.

Losses on the march up to the trenches can be minimized if the stretches of ground which are under fire are crossed in as small parties as possible. One infantry brigade recommends that the relief be carried out by platoons, at short intervals of time, and considers that the troops should move up in file. No hard and fast rules can be laid down. The choice of the formation in which the

troops are to move will always depend on the nature of the ground.

When troops which are advancing are to be relieved, as much engineer and constructional material as possible must be taken up with the relieving troops. In all cases the men must carry as many large entrenching tools as they can.

5. German Communications.

Runners.—When all others fail, the runner still remains as the last means of communication. Numerous runners must be trained to know the ground. Dug-outs should be constructed at intervals along the routes used. Runners should never be sent out singly.

Runners, and the establishment of relays of runners, have proved very useful everywhere. The casualties were comparatively slight. All important information and orders should always be sent in duplicate. One infantry brigade recommends 100 yards as the distance between the relay stations in the fire zone.

Telephones.—The usual practice of changing telephone apparatus when reliefs were carried out proved to be a source of very marked interruption. It must not take place when the fighting is so severe. The outgoing units should hand over their apparatus to the incoming troops.

Light Pistols.—The communication between the front line and the artillery for the direction of barrage fire was entirely confined to light pistol signals.

6. German Rations.

The quantity of "iron rations" in the position was increased to five days' rations. Ample supplies of mineral water, cigars, chocolate and solidified alcohol for warming up food were provided.

The provision of kitchen and store rooms in mined dug-outs and of spare kitchens is necessary.

It is necessary that fresh troops going into the line, when the precise state of the battle is uncertain, should be supplied with the third iron ration.

The formation of carrying parties with baskets, etc., was a great assistance in bringing up rations and also in supplying troops with ammunition and stores. Wherever infantry pioneer companies were used for this purpose, these carrying parties were formed within companies; this has the advantage of the feeling of camaraderie which prevails between such carrying parties and their fighting troops.

7. Miscellaneous.

The infantry pioneer companies of each infantry regiment of the corps proved of great value. Full use, however, was not made of their special training, as the fighting provided them with more urgent work. These companies, which consisted of men of experience and accustomed to work together, proved most valuable in the many difficult and unexpected problems which continually faced the regiments: For instance, in the provision of the front line trenches with the material necessary for carrying on the fight.

The hand grenade was a most important infantry weapon both in attack and defense. It is universally suggested that the supply of hand grenades should be increased.

Entrenching Tools.—Repeated requests from all arms for an increased supply of entrenching tools must be met by the provision of entrenching tools from the reserve depots behind the battle sector.

Dressing Stations.—In the rear of every battalion sector it is advisable to have one bomb-proof medical dug-out with accommodation for thirty wounded, or two dug-outs each for 20 wounded.

8. German training.

The instructions based on our previous experience in defense and attack all took for granted

a carefully constructed trench system. The troops on the Somme found practically no trenches at all.

The front line, and the ground for a considerable distance behind the fighting front was kept under fire by the enemy's artillery; this fire was almost continuous and of a volume never before experienced. Several lessons for the training of the troops were learned as the result of this bombardment; the following are the most important:—

Every individual must be trained to the highest possible degree of self-reliance, so that he may know how to act during the critical periods of his own or the enemy's attacks, when he must generally be left to his own resources and is beyond the control of his superiors.

Crossing ground which is being heavily shelled.

Training of infantry in establishing relays of runners.

Increase in the personnel trained in the use of our own and captured machine guns (officers and men).

Training in the use of all kinds of German hand grenades.

Training as many men as possible in the use of the enemy's hand grenades.

Attacks by sectors, according to time table, following close up to our barrage. Formations organized in as great depth as possible to be able to cope with surprises. The absolute necessity of this has again been proved in attacking in wooded country with a restricted range of vision.

Rapid execution of counter attacks over open ground under different conditions. Bombers in front, skirmishers about ten meters behind them, a number of small bodies in support slightly further in rear. In wooded country these move in file; otherwise in extended order.

Training in the rapid preparation of shell holes for defense, and in digging trenches by small

parties in captured ground. Marching in file to form up on the tracing tape.

The employment of improvised materials in constructing defenses if prepared materials are not available.

(Signed)

General Staff (Intelligence),
General Headquarters,
—th, October, 191—.

Meteorological Data.

Weather Forecasts.

General Indications

Valuable information is contained in the daily weather charts published by the meteorological office and in the various newspapers.

The lines of equal **barometric pressure**, or **Isobars**, show the general distribution of atmospheric pressure, from which the probable winds can be foretold. There are two main types of distribution of the isobars, and with these all other types are more or less intimately associated.

A cyclone, or depression, is a definite area of low pressure, usually characterized by strong winds, rough, unsettled weather, and a temperature low in summer and high in winter. The winds blow spirally toward a low pressure area in an anti-clockwise direction. The motion, as a rule, is from west to east.

An anti-cyclone is a definite area of high pressure, characterized by light airs and calms, dry, hazy or foggy weather, and a temperature high in summer and low in winter. The wind blows outward from the high pressure area in a clockwise direction. It has no general direction of motion.

The center of a cyclone is a general area of ascending air currents, and that of an anti-cyclone of descending air currents.

The **intervals between the isobars** usually correspond to differences in pressure of one-tenth of an inch. A cyclone with crowded isobars always has strong winds; when the isobars are widely spaced the winds are gentle.

Cyclones are usually preceded by rising temperature and accompanied by cloudiness and rain and snow.

Anti-cyclones are usually preceded by falling temperature and attended by fair weather.

Forty-eight hours is about the present limit of the possibilities of forecasting the weather with any degree of accuracy. Forecasts for a week in advance are made by meteorological offices, with the aid of reports from a chain of stations extending around the world, but these are bound at present to be in very general terms.

Regarding weather fallacies, it is interesting to note that from the point of view of a meteorological expert, there is no permanent or progressive change in weather or weather conditions—one year may differ from another, but the averages over many years are constant. The equinoctial gales are a myth of the uninitiated, and further, the moon has nothing whatever to do with weather conditions.

Local Indications.

(England)

Local indications which assist in a forecast are the behavior of the barometer and thermometer and the aspect of the sky and clouds.

Barometer.

Rapid rise.

Unsettled weather, liability to sudden changes.

- Gradual rise.** With a dry atmosphere, fair weather; after southerly winds, improving tendency with wind from W. or N.W.
- Rise after being low.** First rising usually precedes heavy winds from the northward; continued rising indicates improving weather.
- Rise after being normal.** With falling temperature and dry atmosphere, wind from N. E., N. or N. W. or less wind.
- Steadiness.** With dry atmosphere fine weather.
- Rapid fall.** Stormy weather and rain. If with westerly wind, storms from southwards.
- Considerable fall.** High wind, rain or snow, wind from N. if thermometer is low; from S. if it is high.
- Fall after being normal.** With rising thermometer and increasing dampness, wind from S. E., S., or S. W.; if the thermometer is low, snow.
- Fall.** After northerly winds, bad tendency, wind probably shifting to south. With high or increasing

temperature, winds from S. or S.W., possible rain.

The barometer generally falls with a south and rises with a north wind; if the opposite happens, the south wind will be dry and the weather fine, or the north wind will be strong and will bring rain. Fine weather with a low barometer is usually followed by a duration of wind or rain.

Clouds.

- Cirrus.** Consists of flexuous fibres extending in any direction. Mares-tail clouds usually indicate coming wind.
- Cirro-stratus.** A flat widely extended cloud. A "mackerel" sky is an example—sign of rain or snow.
- Cirro-cumulus.** Small, well-defined rounded masses in close horizontal arrangement. A forerunner of storms.
- Cumulo-stratus.** A mixture of the cirro-stratus and the cumulus; may turn to nimbus, but often evaporates.
- Nimbus.** Usually formed from cumulo-stratus; a dense black cloud with ragged edges, from which rain is falling.

Cumulus. Convex or conical heaps rising from horizontal base; fair weather clouds when small, showery when large and piled up; when very large and ragged at the top, cause local thunder storms.

Stratus. A widely extended, horizontal cloud, which increases from below. Includes some mists and fogs.

Cirrus and cirro-stratus clouds, whose altitude above sea-level averages about five miles, consist of minute crystals of ice; all other clouds are composed of fine particles of water.

Neither crystals nor drops actually float in the air. They are constantly falling with respect to the air around them, though as the air itself often has an upward movement the cloud particles are not always falling with reference to the earth. The fact is of considerable interest to aviators.

A fog is a cloud lying at the earth's surface.

In general, soft looking clouds accompany fine weather, and those with clear and well defined edges presage wind. Ragged clouds and light scud are the forerunners of strong wind and rain.

Color of Sky, Etc.

Red at sunset..... Rain.
Red at dawn..... Wind.
Grey at dawn..... Fair weather.
Bright yellow at sunset.... Bad weather, or wind.
Pale yellow at sunset..... Fair weather.

A high dawn (first light behind a bank of clouds) foretells wind, and an unusual clearness of the atmosphere near the horizon is a very sure sign of rain.

The following table is given in many almanacs as indicating the kind of weather which will most probably attend the moon's entrance into any of her quarters. It must, however, be regarded as rather empirical:

Time of Moon's Entrance.	In Summer.	In Winter.
Between: 12 midnight & 2 A.M.	Fair.	Hard frost, unless wind S. or S.W.
2 A.M. & 4 A.M.	Cold with showers.	Snow and stormy.
4 A.M. & 6 A.M.	Rain.	Stormy with rain.
6 A.M. & 8 A.M. 8 A.M. & 10 A.M.	Wind and rain. Variable.	Stormy. Rain if wind W., snow if East.
10 A.M. & 12 Noon.	Showery.	Cold and high wind.
12 Noon & 2 P.M. 2 P.M. & 4 P.M.	Very rainy. Variable.	Snow or wind. Fair and mild.
4 P.M. & 6 P.M. 6 P.M. & 8 P.M.	Fair. Fair if wind N.W., rainy if S. or S.W.	Fair. Frosty if wind N. or N.E., snow if S. or S.W.
8 P.M. & 10 P.M. 10 P.M. & 12 Midnight. Fair. Fair with frost.

Hours of Moonlight.

When the moon is	4 days	old,	it shines till about	10 P.M.
"	"	5	"	11 P.M.
"	"	6	"	12 P.M.
"	"	7	"	1 A.M.
When the moon is	15 days	old,	full moon rises about	6 P.M.
"	"	16	"	7 P.M.
"	"	17	"	8 P.M.
"	"	18	"	10 P.M.
"	"	19	"	11 P.M.
"	"	20	"	12 P.M.

HEIGHT OF TRAJECTORY (in feet) ABOVE THE LINE OF SIGHT
THE S. M. L. E. MARK III RIFLE.
MARK VII ammunition—M. V. 2440 f. s.

RANGE IN YARDS	HEIGHT IN FEET													
	200	300	400	500	600	700	800	900	1000	1100	1200	1300	1400	
200														
300	.6													
400	1.3	1.0												
500	2.1	2.3	1.7											
600	3.1	3.8	3.7	2.5										
700	4.3	5.6	6.1	5.5	3.6									
800	5.7	7.6	8.8	8.9	7.6	4.8								
900	7.3	10.0	12.0	12.8	12.4	10.3	6.3							
1000	9.1	12.7	15.5	17.5	17.8	16.8	13.5	8.2						
1100	11.2	15.8	19.7	22.7	24.1	24.1	22.0	17.6	10.5					
1200	13.5	19.4	24.4	28.6	31.1	32.4	31.4	28.3	22.2	12.9				
1300	16	22	30	35	39	42	42	40	36	28	16			
1400	19	28	36	43	48	53	54	54	51	45	35	20		
1500	23	33	43	52	59	64	68	69	68	63	55	42	24	
1600	26	39	50	61	70	78	83	86	87	84	77	66	50	
1700	31	45	59	71	82	92	99	105	108	107	103	94	79	
1800	35	52	66	83	96	108	118	126	131	132	130	124	112	
1900	40	60	78	96	112	127	136	149	157	161	161	157	148	
2000	46	68	90	110	129	146	162	175	185	192	195	194	188	
2100	52	78	102	125	147	168	186	202	216	226	232	234	230	
2200	59	88	116	143	168	192	214	233	250	264	273	278	278	
2300	67	99	131	161	190	218	243	267	287	305	318	326	330	
2400	75	111	147	181	215	246	276	305	328	349	366	379	386	
2500	84	124	164	204	241	277	311	343	372	397	419	436	448	
2600	93	139	184	228	270	311	349	386	420	450	477	498	515	
2700	104	155	205	254	303	348	392	433	472	507	540	566	588	
2800	115	172	228	282	336	388	437	484	529	570	607	640	667	

	1500	1600	1700	1800	1900	2000	2100	2200	2300	2400	2500	2600	2700
1600	28												
1700	59	33											
1800	94	70	39										
1900	133	112	83	46									
2000	175	157	131	97	54								
2100	221	206	183	152	112	62							
2200	272	261	241	214	177	129	71						
2300	328	319	304	280	246	203	148	81					
2400	388	384	372	353	323	283	233	169	92				
2500	459	454	447	433	406	370	324	265	193	105			
2600	526	531	528	517	496	465	424	369	301	218	118		
2700	604	613	616	609	594	568	532	482	419	340	245	133	
2800	689	704	711	711	700	680	649	604	547	474	384	277	149

NOTE:—The trajectories of the other patterns of rifle may be taken as practically identical with the above table.

HEIGHT OF TRAJECTORY (in feet) ABOVE THE LINE OF SIGHT
 THE S. M. L. E. MARK 111 RIFLE
 MARK SEVEN ammunition—M. V. 2.060 f. s.

RANGE IN YARDS	HEIGHT IN FEET												
	200	300	400	500	600	700	800	900	1000	1100	1200	1300	1400
200													
300	1.0												
400	2.1	1.7											
500	3.4	3.7	2.6										
600	4.9	5.9	5.6	3.7									
700	6.5	8.4	8.9	7.8	5.0								
800	8.4	11.1	12.8	12.4	10.5	6.4							
900	10.5	14.3	16.8	17.7	16.8	13.7	8.4						
1000	12.8	17.8	21.5	23.6	23.8	22.0	17.8	10.6					
1100	15.4	21.7	26.7	30.0	31.7	31.2	28.4	22.4	13.1				
1200	18.3	26.0	32.5	37.3	40.3	41.2	39.8	35.3	27.5	15.8			
1300	21	31	39	45	50	52	52	49	43	33	19		
1400	25	36	46	54	60	64	66	65	60	52	39	22	
1500	29	41	53	63	71	77	81	82	79	72	62	46	26
1600	33	48	62	73	84	92	98	100	99	95	86	73	55
1700	37	54	70	84	97	107	115	120	122	119	113	102	86
1800	42	62	80	97	111	124	134	142	146	146	142	133	120
1900	47	69	90	109	127	142	155	165	172	174	173	167	155
2000	53	78	101	123	143	161	177	190	190	205	206	203	194
2100	59	86	113	138	161	182	201	216	229	237	241	241	235
2200	65	96	125	154	180	204	226	245	260	271	278	282	279
2300	72	106	139	170	200	227	252	274	293	307	318	324	325
2400	79	116	153	188	221	250	280	306	328	346	360	369	374
2500	86	128	168	207	243	278	311	340	366	387	405	418	427
2600	94	140	184	227	268	307	343	367	406	432	453	471	483
2700	103	153	202	249	295	338	379	416	450	481	507	528	545
2800	115	168	222	274	324	372	418	460	499	534	566	592	612

	1500	1600	1700	1800	1900	2000	2100	2200	2300	2400	2500	2600	2700
1600	31												
1700	64	36											
1800	100	74	41										
1900	139	115	85	46									
2000	180	159	131	96	52								
2100	224	206	181	108	108	58							
2200	270	256	234	204	167	120	65						
2300	320	308	289	263	229	186	134	72					
2400	372	364	348	326	296	255	206	148	79				
2500	429	424	412	393	366	330	285	230	165	90			
2600	489	488	481	465	442	410	369	318	257	185	99		
2700	555	558	555	545	522	497	461	414	357	290	208	113	
2800	627	636	637	631	616	594	561	519	467	405	327	237	128

CONTENTS

Chapter I. The Intelligence Section.....	Page 3
Chapter II. Military Map Reading.....	Page 17
Chapter III. Instruments and Equipment.....	Page 61
Chapter IV. Information, Reconnaissance and Observation.	Page 75
Chapter V. Reports, Messages and Orders.....	Page 89
Chapter VI. Trench Warfare	Page 111
Chapter VII. Aeroplanes and Air Photos.....	Page 127
Chapter VIII. General Information	Page 141

ILLUSTRATIONS

	Page
Canadian Intelligence Section.....	Frontispiece
Curves of Magnetic Variation 1917.....	Insert 2-3
French Military Map.....	19
Canadian Training Map.....	21
German Map	Insert 22-23
English Artillery Training Map.....	23
Scales	25
Folding Contour Map (Cross Sections).....	Insert 30-31
Contour Demonstration	32
Conventional Signs	Insert 34-35
Traversing	" 41-42
Map Reading and Machine Gunners Protractor.....	46-47
Compass error tag.....	52
Squared Service Map—Explanation of Method.....	Insert 52-53
Squared Service Map.....	57
Mark VII Service Prismatic Compass (English).....	Insert 62-63
Liquid Prismatic Compass (English).....	63
Trench Sniperscope	Insert 66-67
Light Fixed Rifle Stand.....	" 70 71
Diagram Trench Raid.....	" 84-85
Trench Map, Snipers and Observation Posts Shown.....	" 112-113
Snipers Posts in Parapet.....	114-115
Intelligence Section Dug-Out Fig. 1.....	Insert 116-117
Intelligence Section Dug-Out Fig. 2.....	" 118-119
Observation Posts Under Wire Entanglement Fig. 1.....	" 120-121
Observation Posts Under Wire Entanglement Fig. 2.....	" 122-123
Aeroplane Photograph	129
Indirect Fire by Fixed Rifles.....	Insert 130-131
Sky Views Aeroplanes and Airships.....	" 132-133
Aeroplane Emblems	" 134-135
Gas Mask (English).....	143
Compass "Rose"	155

The New Platoon Instructor

By Captain T. H. Gillman, C. E. F.

Up to the minute and full of information on training under the new **Platoon Formation**. Includes special chapters on bombing, rifle grenades, bayonet fighting, Lewis machine guns and other automatic rifles, anti-gas measures, modern trench construction, wire entanglements and range finding, etc., all of which information must be mastered to insure the perfect infantry platoon. Fifty-six sketches, colored plates and photographs.

Captain Gillman is just back from France after spending two years in active service. Military authorities concede that this book will be of invaluable service at this time as an aid to military training. A careful study of same will hasten your promotion.

Price per volume \$2.50

Full flexible Leather cover.

Remit by Registered Letter, Money Order or
Bank Draft.

EDWARD C. MCKAY

409 Swetland Building
CLEVELAND, OHIO

Map Reading and Machine Gunner's Protractor

Designed by Captains C. D. A. Barber and T. H. Gillman, C. E. F.

No infantry or machine gun officer, non-commissioned officer or man can afford to be without it.

Protractor is made of circular transparent celluloid, eight inches in diameter and one thirty-second of an inch thick. Has been cleverly designed to read, measure and solve every problem in military map reading and machine gunnery by simply placing it over your map and immediately before your eyes is the range, the choice of proper trajectory to clear obstacles and compass bearing.

On the face of the protractor are tables and formulas for overcoming the difficulties in indirect fire.

A novice can use it accurately in ten minutes. Made of one piece of celluloid. No book to study. Calculations made almost instantly.

Compass bearings transposed to and from maps at sight. Scale to degrees and minutes or miles. Trajectory diagram. Angle of wind and drift tables. Designed for use of United States ammunition.

Teaches how to transpose magnetic and true bearings.

Price, \$2.00 each.

Remit by Registered Letter, Money Order or Bank Draft.

EDWARD C. McKAY,

409 Swetland Bldg.

Cleveland, Ohio.

MACHINE GUN FIRE CONTROL

By Capt. Glenn P. Wilhelm, 4th U. S. Infantry

A complete text book, fully illustrated, of the use of the Mil system in the control of Machine Gun Fire with particular reference to modern trench warfare methods.

For beginners as well as experts. All terms are fully defined and illustrated. Tells how to calculate ranges and elevations from contoured maps for Indirect Fire. Valuable tables are in the book to be found in no other publication.

Do you know how to elevate and direct your Machine Gun in order to safely fire over your own troops at an invisible enemy trench over a hill?

Do you know what elevation and direction to use on your Machine Gun in order that you may fire over your own front line trenches and search with long range fire enemy supply dumps and communications on the reverse slope of a hill?

This book tells you how.

THE MILOMETER OR BALLISTIC COMPUTING SLIDE RULE

Have you a natural dislike for mathematical data required for indirect fire? If so, you need this book which is furnished with a most ingenious fire control slide rule that will mechanically figure ranges, measure angles, determine widths, calculate any sight setting or elevation for direct fire, indirect fire, searching fire, combined sights, overhead fire, barrage fire, night firing, etc., and determine all manner of fire control and map problems.

Will do all any mil scale will do and more.

Will do all any fire control computing slide rule will do and more.

The Milometer is constructed on the usual rectangular slide rule design and is simple in appearance and operation.

EXCLUSIVE FEATURES

Common or Mannheim style of slide rule similar to majority of slide rules.

Mil and trajectory scales are on the same side of rule.

Direct reading scales for angles of departure and angles of fall.

Six-inch scale in inches and tenths of inches.

Twelve-inch scale in inches and sixteenths inches.

Fifteen-centimeter scale in millimeters.

Least reading on mil scale is two mils, by estimation one mil.

Rectangular protractor reading to one degree.

Fourteen formulas for range, mil scale and indirect fire.

Mechanically converts metric units to English and vice versa, with the conversion indexes on the rule.

Made of heavy white celluloid. Graduations cannot be obliterated by wear or soiling as the face of the rule is protected by transparent celluloid.

Each rule is equipped with a catgut cord conveniently located for use with either the mil scale, the protractor or as a slope board.

PRICE \$2.50, INCLUDES SLIDING RULE

PRICE \$1.75 FOR BOOK OR RULE SEPARATE

Remit by Registered Letter, Money Order or Bank Draft

Published and For Sale by

EDWARD C. McKAY

409 SWETLAND BUILDING,

CLEVELAND, OHIO

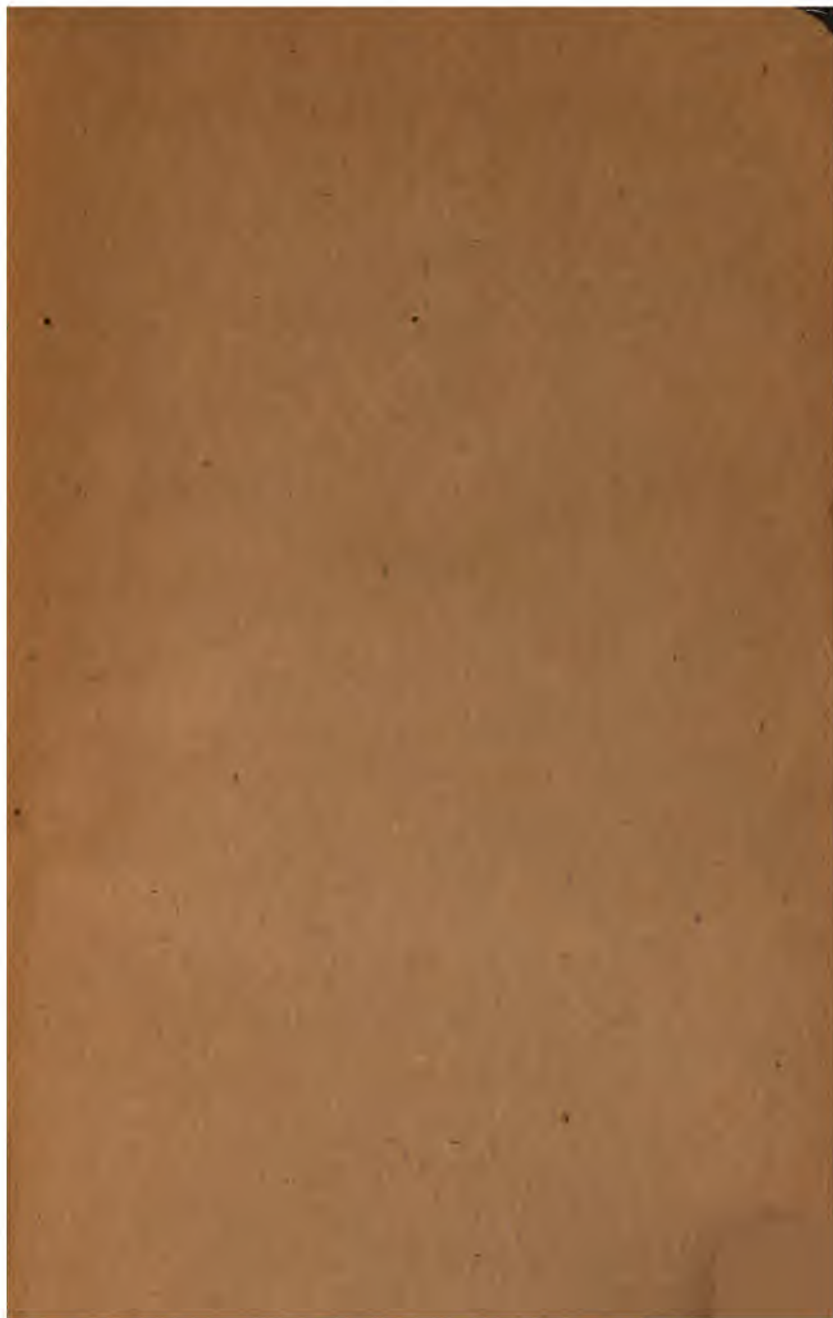

YB 04301

369564

Barber

UGA 70

B3

UNIVERSITY OF CALIFORNIA LIBRARY

